

EDP90

225 to 500kVA

UNINTERRUPTIBLE POWER SYSTEM

Restricted Sales Distribution

WARNING: This is a product for restricted sales distribution to informed partners. Installation restrictions or additional measures may be needed to prevent radio interferences.



**User Handbook
10H52111PU9C rev.1**

PRELIMINARY INFORMATION

The EDP90 Uninterruptible Power System USER HANDBOOK is a single-volume source of information. **Consult the handbook prior to operating the EDP90 UPS. Particular attention must be paid to the information given on the following page.**

This manual must be consulted prior to connecting up to the power supply; connections must be made by a qualified electrician with experience in the installation of electrical equipment.

This handbook contains information for the installation, start up and operation of the Uninterruptible Power System (UPS) unit, model EDP90. Information is divided into, chapters the following System:

- Chapter 1 describes operations to be performed during delivery and storage of the unit;
- Chapter 2 describes the necessary characteristics of the room in which the UPS is to be installed;
- Chapter 3 describes the UPS mechanical characteristics and installation data in general;
- Chapter 4 describes POWER SUPPLY-UPS, UPS-UPS, and UPS-LOAD connections;
- Chapter 5 describes UPS operation modes;
- Chapter 6 describes UPS controls;
- Chapter 7 illustrates diagnostics for single and parallel UPS units;
- Chapter 8 describes POWER HISTORY use;
- Chapter 9 describes GUIDED PROCEDURE operations;
- Chapter 10 describes I/O CONFIGURATIONS (SETUPS);
- Chapter 11 illustrates the BATTERY AUTONOMY TEST;
- Chapter 12 describes UPS/ computer INTERFACING;
- Chapter 13 describes UPS REMOTE ALARMS.

The last page of the handbook has been reserved for user's observations. All suggestions, indications of errors or omission will be appreciated. This information should be sent to the following address:

CHLORIDE POWER ELECTRONICS

126 Chloride Road

Burgaw

N.C. 28425

U.S.A.

Tel. 1-910-259-1000

Fax 1-910-259-1106

CHLORIDE POWER ELECTRONICS reserves the right and exclusive use of any observation or suggestion received.

Guarantee and Responsibility limitations

The Manufacturer, having made every effort to ensure the accuracy of the information given in this handbook, declines all responsibility for any direct or indirect damage (including profit loss) caused by this publication or the information therein.

This document is for information only. The Company's policy is of continual improvement of its products therefore CHLORIDE POWER ELECTRONICS reserves the right to alter any part of the information herein contained without prior notice.

IMPORTANT SAFETY INSTRUCTIONS

READ BEFORE INSTALLING

1) SAVE THESE INSTRUCTIONS

This manual contains important instructions for the EDP90 Series which should be followed during installation and maintenance of the UPS and its associated batteries.

- 2)** Installation must be inspected by trained electricians.
The instructions must be followed.
- 3)** When external batteries are provided by the Customer and not the Supplier, reference must be made to the installation instructions provided by the battery Supplier.

WARNINGS

- 1)** The AC and DC supplies to the EDP90 Series UPS and the AC output from the UPS **MUST** be fed through suitably rated circuit breakers or fuses and isolating switches suitable for branch circuit operation.
- 2)** Any external battery cabinet connected to the UPS **MUST** be provided with an overcurrent protection device per UL1778 Par. No. 10.4.
- 3)** To reduce the risk of fire or electric shock, the equipment must be installed indoors, in a humidity and temperature controlled environment free from conductive contamination.

SAFETY

- 1)** **DO NOT REMOVE COVERS DURING NORMAL OPERATION.** The panels will be removed during installation, however this should be undertaken only by qualified electricians.
- 2)** **FOREIGN OBJECTS MUST NOT BE INTRODUCED INTO VENTILLATION GRILLES.**
HAZARDOUS VOLTAGES are present within the UPS even when it is switched off.
- 3)** Fuses must only be replaced with the same type and rating.
- 4)** The EDP90 contains a sealed battery which can be **DANGEROUS** if interfered with. Contact Supplier for replacement.
- 5)** The UPS and/or its components must be disposed of as notifiable waste in accordance with local pollution control (special waste) regulations.

WARNING



The UPS contains hazardous voltages, even when all switches are open. In case of fire in the installation area, do not use water to extinguish fire.

ELECTRICAL PRECAUTIONS:

If the UPS is in Maint. mode and the Output switch is closed, no indications will be displayed; fans will however function, and hazardous voltages will be present downline from the static switches.

CAUTION

It should be ensured that the UPS is switched off and all power sources disconnected (A.C. Utly and battery) before either rear or side panels are removed.

The battery switch **MUST NOT BE OPERATED** during battery discharge. The inverter must be switched off before commencing this operation.

EMERGENCY PROCEDURE

In the case of an emergency, the load supply can be interrupted by switching off all the circuit breakers fitted in the UPS.



ELECTRIC SHOCK

Switch off power; use dry insulating material for protection when pulling injured person clear of conductors. NEVER TOUCH THE INJURED PERSON WITH BARE HANDS UNTIL CLEAR OF CONDUCTORS. SEEK QUALIFIED ASSISTANCE IMMEDIATELY.



INJURIES CAUSED BY CONTACT WITH CORROSIVE LIQUIDS

In normal conditions, installed batteries are dry. A damaged battery container may however leak electrolyte, or cause the latter to come into contact with battery parts.

In the event of electrolyte contact with the eyes, rinse eyes thoroughly with a saline solution or fresh water for at least 10 minutes.

In the event of electrolyte contact with skin, rinse the affected area with abundant water. Remove contaminated clothing. Cover affected area with dry gauze.



If electrolyte is swallowed, do not induce vomiting. Administer large quantities of milk or water.

IN ALL CASES, SEEK MEDICAL ATTENTION IMMEDIATELY

Contents

INTRODUCTION.....	7
1. EQUIPMENT DELIVERY AND STORAGE.....	7
1.1 Delivery.....	7
1.2 Unpacking.....	7
1.3 Handling.....	7
1.4 Storage.....	10
2. PREPARATIONS FOR INSTALLATION.....	11
2.1 Floor loading.....	11
2.2 Access to the area.....	11
2.3 Dimensions of the area.....	11
2.4 Ventilation.....	11
3. INSTALLATION.....	13
3.1 UPS installation data.....	13
3.2 Single UPS electrical connections.....	20
3.3 Distributed parallel system electrical connections.....	21
3.4 Protection devices.....	22
3.5 PE connection.....	23
3.6 NEUTRAL connections.....	23
3.7 GENERATOR power supply.....	23
3.8 Separate BYPASS.....	24
3.9 Non linear LOADS.....	25
3.10 Battery commissioning and installation.....	26
4. CONNECTIONS.....	27
4.1 Recommended cable sizes.....	27
4.2 Data for power connections of single and distributed parallel UPS.....	28
4.3 300 and 400kVA UPS connections.....	29
4.4 300 and 400kVA UPS power and signal connections view.....	30
4.5 500kVA UPS connections.....	31
4.6 500kVA UPS power and signal connections view.....	32
4.7 Customer Side Terminations.....	33
4.8 INDIVIDUAL UPS signal connection information.....	35
4.9 Signal connections data: DISTRIBUTED parallel UPS.....	36

5. DESCRIPTION OF SYSTEM.....	39
5.1 Equipment.....	39
5.2 Functions.....	40
5.3 Operating modes.....	41
6. UPS CONTROLS.....	43
6.1 User controls.....	43
6.2 Control panel.....	44
7. EDP90 DIAGNOSTICS FOR SINGLE OR PARALLEL UPS.....	45
7.1 UPS messages normal description.....	46
7.2 Description of system stages (status, alarms, measurements).....	52
7.3 RECTIFIER stage description.....	55
7.4 BATTERY stage description.....	56
7.5 INVERTER stage description.....	58
7.6 BYPASS stage description.....	60
7.7 LOAD stage description.....	61
8. POWER HISTORY.....	63
9. GUIDED PROCEDURE.....	65
9.1 EDP90 Single unit.....	65
9.3 EDP90 DISTRIBUTED Parallel system.....	73
10. EDP90 I/O FUNCTIONS.....	92
10.1 Description of input/output functions.....	92
10.2 Available functions.....	92
10.3 How to activate the functions.....	97
10.4 Description of function wiring with fixed terminal assignments.....	102
10.5 Special notes.....	105
10.6 Battery isolation voltage.....	105
10.7 Electrical specifications of input/output signals.....	105
10.8 Table of functions activated on individual or parallel UPS.....	106
11. BATTERY TEST.....	108
11.1 AUTONOMY TEST.....	109
12. COMPUTER INTERFACE.....	111
12.1 INTERFACE CONNECTORS.....	111
12.2 AS400™.....	111
12.3 RS232 - COM1.....	113
12.4 RS232 - COM2.....	113
13. REMOTE ALARMS.....	114

INTRODUCTION

Scope

This handbook provides instructions for the installation, start up and use of the EDP90 Uninterruptible Power System (UPS) 300-500kVA. Chloride recommends installation and regular servicing by Chloride service engineers or authorised electricians.

- DO:**
- read the User Handbook prior to operating the EDP90 UPS.
 - keep a log of all faults.
 - protect batteries against damage. Leaked acid is highly corrosive; avoid contact with skin, eyes and clothing.
- DO NOT**
- operate the control switches.
 - operate the system with panels removed.
 - obstruct the ventilation grilles.

1. Equipment delivery and storage

1.1 Delivery

The equipment and battery are delivered separately. On receipt, the packaging must be checked for any signs of damage. Any damage or missing parts should be reported to the carrier immediately.

1.2 Unpacking

Care should be taken when unpacking to avoid damaging the equipment or battery; in particular, avoid short circuiting battery terminals. All packing materials should be checked before disposal to ensure that no items are discarded. The equipment panel rating plate should be checked to ensure that supply voltage and output rating correspond to the equipment and load and that the mode of operation is correct.

1.3 Handling

Keep equipment and battery upright at all times, and handle with care. Either may be damaged if dropped or subject to severe impact. Particular care should be taken to protect the controls and instruments.

- a) Leave the equipment in its packaging and transport it with a fork lift (figure a).
- b) Remove the box and the plastic by pulling it upwards. (figure b).
- c) Remove the bolts fastening the pallet to the cubicle feet.
- d) Lift the cubicle and remove the pallet.

a

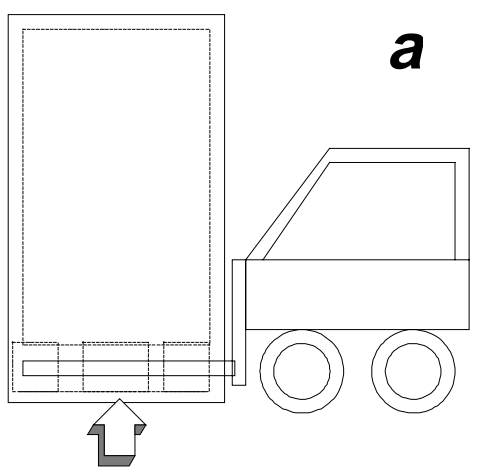

b

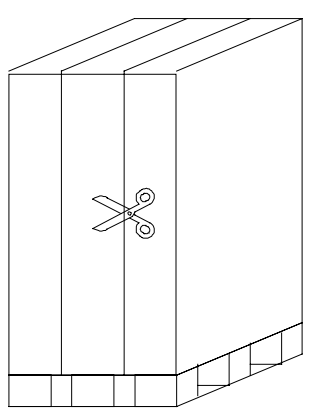

c

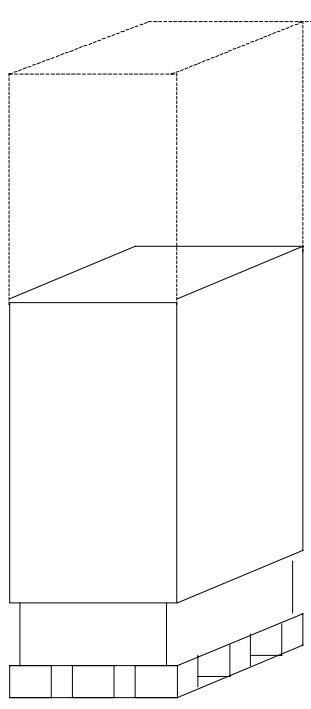

d

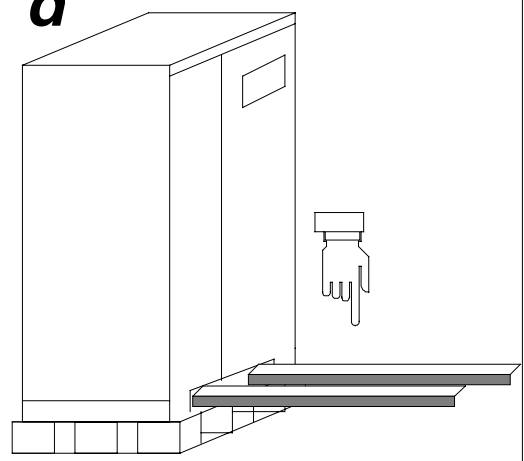

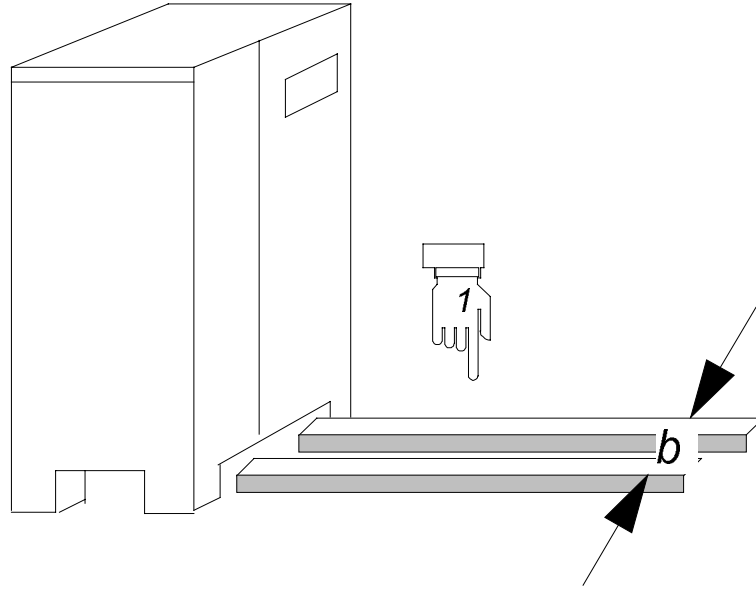

*UPS ratings [kVA]
(Basic modules)*

*max. dimensions
of b (mm)*

300-400

27.6 in. (700mm)

500

43.3 in. (1100mm)

1.4 Storage

Store the equipment and battery in a clean, dry place, protected from water, condensation, dirt and extremes of temperature. Batteries must be maintained in accordance with the Manufacturers Instructions supplied with the battery.

Sealed lead acid battery cells which are supplied filled and charged must be given a boost charge at least every 3 months.

In the case of wet cell-type batteries the level of the electrolyte should be checked before and after charging.

Sealed nickel-cadmium battery cells which are supplied filled and discharged must be charged and discharged before storage.

Sealed nickel-cadmium battery cells which are supplied dry must be filled, charged and discharged before storage.

Sealed replacement battery cells must be charged at least every 3 months.

Failure to comply with the Manufacturer's instructions may result in the battery not reaching its rated performance and having a shortened life.

2. Preparations for installation

2.1 Floor loading

The weight of the various UPS systems are given in the tables below. Choose an installation site with the correct floor loading to support the weight of the equipment. In case of uncertainty seek expert advice.

2.2 Access to the area

The installation site must have sufficient space for installation maneuvers; the dimensions of the access doors must be sufficiently large to permit passage of the unit. Use a pallet truck to transport the UPS.

Maximum equipment dimensions are given in figures A, A1, B, B1 and C.

2.3 Dimensions of the area

Sufficient space must be left around the UPS to facilitate routine maintenance. A space of 16" must be left between the top of the UPS and the ceiling of the installation site.

In the case of parallel systems, cubicles may be positioned according to customer specifications. The distance between the UPS1 = **PARALLEL CONTROL** and the other UPS must not exceed 100'.

The minimum dimensions of the installation room may be calculated on the basis of this data and the dimensions of the cubicle (figures A, A1, B, B1 and C).

2.4 Ventilation

The range of temperature recommended for correct functioning of the UPS is between 32°F to 104°F (0° C and 40° C), though ideally the ambient temperature should not exceed 77°F (25° C). The heat generated by the UPS is extracted by internal fans and expelled into the air.

N.B. Average temperatures above 77°F (25° C) will shorten battery life; a 15°F (10° C) average increase will halve battery life. The ideal ambient temperature is 77°F (25° C). Heat can be extracted from the UPS site by:

1. A ventilation system (forced cooling)
2. An air-conditioning system

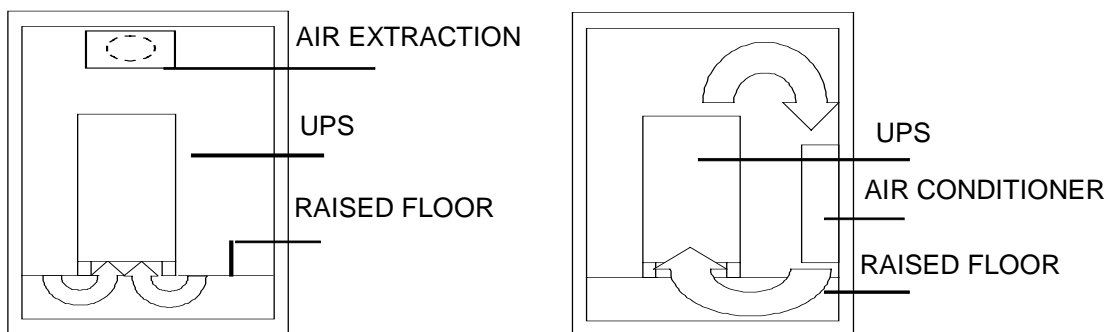

Hourly air cooling requirements will depend on the total of dissipated power (i.e. depending on the type and number of UPS installed) and on cooling air temperature. To calculate the required air flow for the amount of power dissipated, use the following equation:

$$\bar{V} = 2770 \frac{P_d}{T_r - T_k} \cdot e^{(0.125hT_k/T_0)}$$

P_d = Dissipated power in kW

T_r = Maximum temperature permitted on site = 313° K

T_k = Cooling air temperature in °K

T_0 = 273° K

h = Altitude above sea level (in km)

The figure below shows some typical curves of the air flow for different temperature gradients.

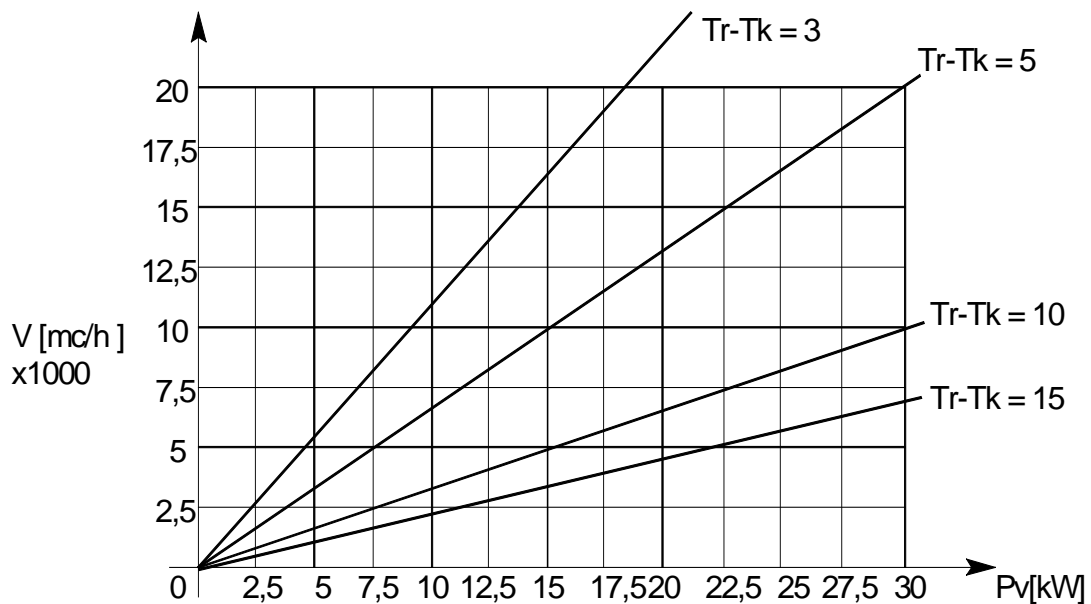

N.B. °K = °C + 273

°F = °C x 1.8 + 32

e = 2.718

3. INSTALLATION

3.1 UPS installation data

- Ambient temperature 32 - 104°F (0 - 40° C)
- Relative humidity (w/o condensing @ 20° C) 90 %
- Max. altitude (w/o derating) 3300 ft. (1000m)
- Protection degree (with opened doors) IP 20
- Input cable bottom or side
- Air inlet bottom
- Air outlet top

Table 1 - UPS INSTALLATION DATA

DESCRIPTION	Units of measurement	UPS Ratings		
		225/250/ 300 kVA	350/400 kVA	450/500 kVA
Weight 6 step	lb (kg)	4180 1900	5060 2300	6380 2900
Weight 12 step	lb (kg)	4530 2060	5390 2450	6670 3030
Floor loading 6 step	lb/in ² (kg/m ²)	1.6 1100	1.92 1358	1.74 1230
Floor loading 12 step	lb/in ² (kg/m ²)	1.72 1216	2.05 1446	1.82 1285
Max. air flow of fans	ft ³ /min (m ³ /h)	3400 5800	3800 6500	4800 8100
Max. dissipation (@ nominal load and battery recharging)	(kW) (kcal/h) (BTU/h)	18.70 16082 63846	23.02 19797 78594	28.78 24751 98261
Max. audible noise level (@ 3ft)	(dBA)	70	73	75

STANDARD FINISH:	LIGHT GREY BLACK	RAL 7035 (frame and panels) RAL 7010 (base)
------------------	---------------------	--

TABLE 2 – UPS RATINGS INFORMATION

Description	Unit of Measure.	EDP90 UPS Rating						
		225	250	300	350	400	450	500
Output Power	kVA	225	250	300	350	400	450	500
Nominal Load	kW	180	200	240	280	320	360	400
Max. I/P Power Demand (@ nominal load and batteries recharging)	kVA	304	338	407	473	540	612	680
Max. Heat Dissipation (Inverter @ nominal load and batteries recharging)	kW	21.9	24.3	29.3k	34	36.7k	44.1	46.2k
	kcal/h	18.8	20.9	25.2k	29.3	31.6k	37.9	39.7k
	BTU/h	74.7k	83k	100k	116.2k	125.2k	150.4k	157.6k
Recommended Number of Battery Cells		240						
Battery Voltage Range	V	396 – 552						
Battery End of Discharge Current	A	489	543	651	760	870	977	1086

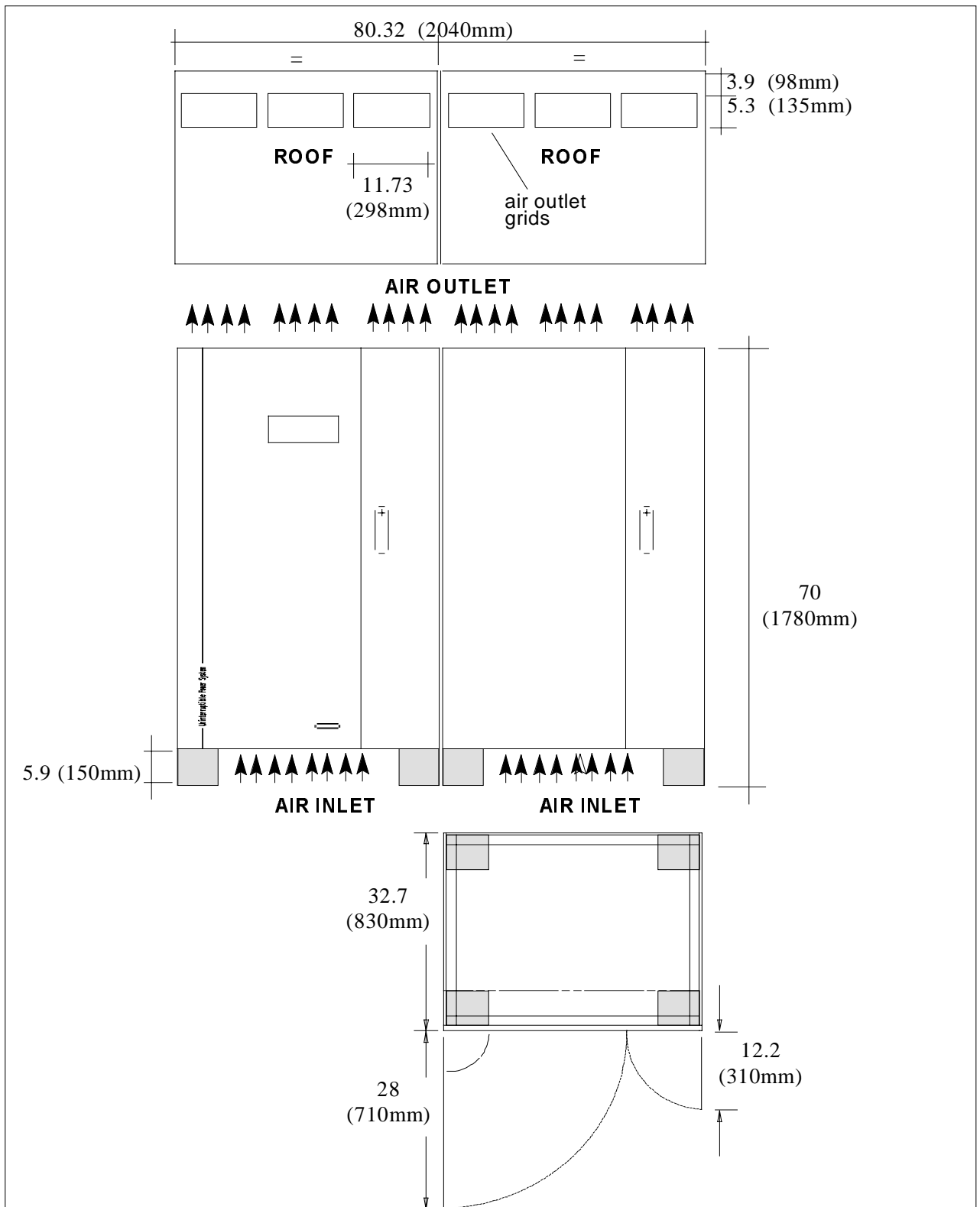

Figure A - Dimensions of UPS ratings 225 through 400kVA in inches (and millimeters)

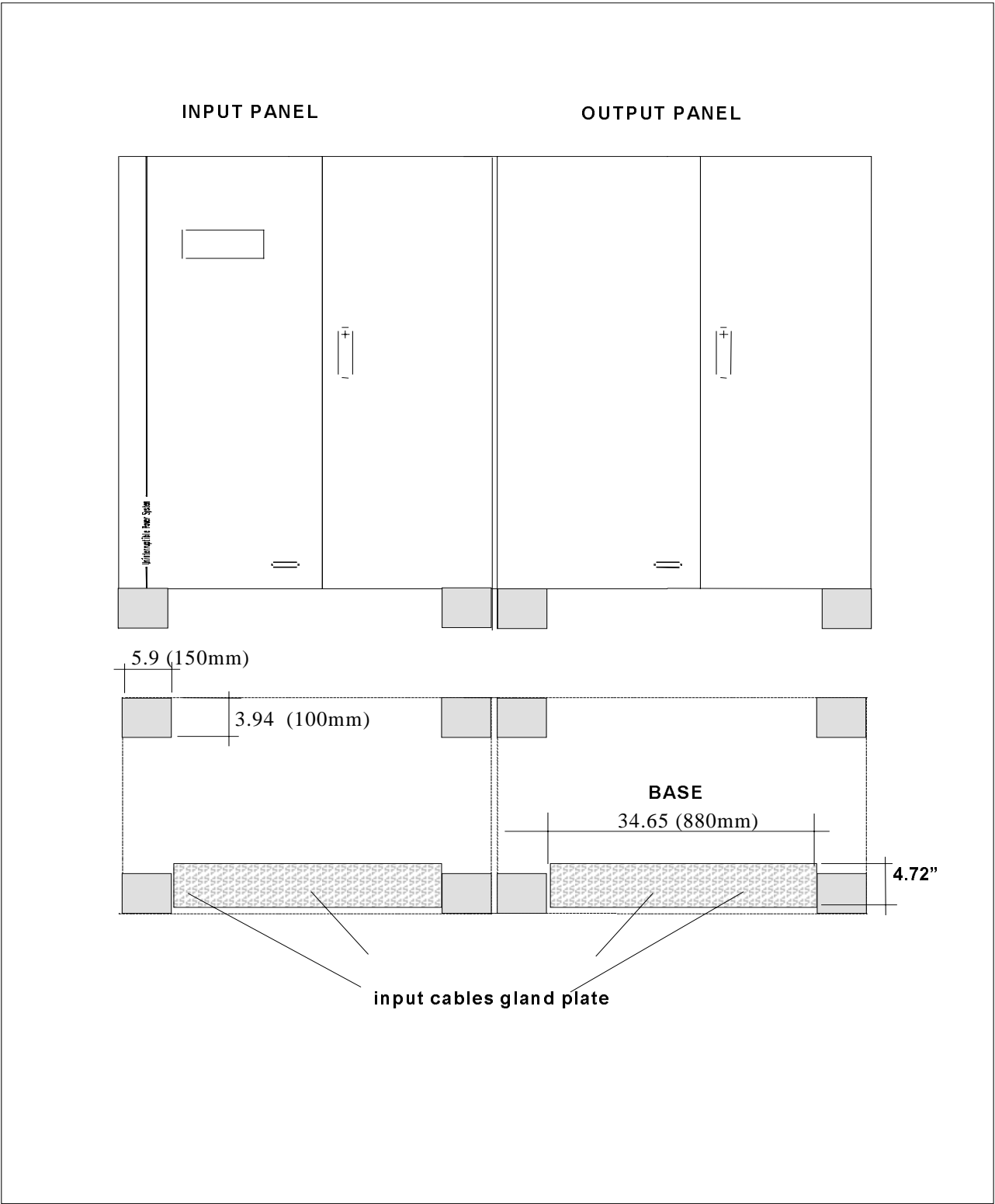

Figure B - Dimensions of UPS ratings 225 through 400kVA in inches (and millimeters)

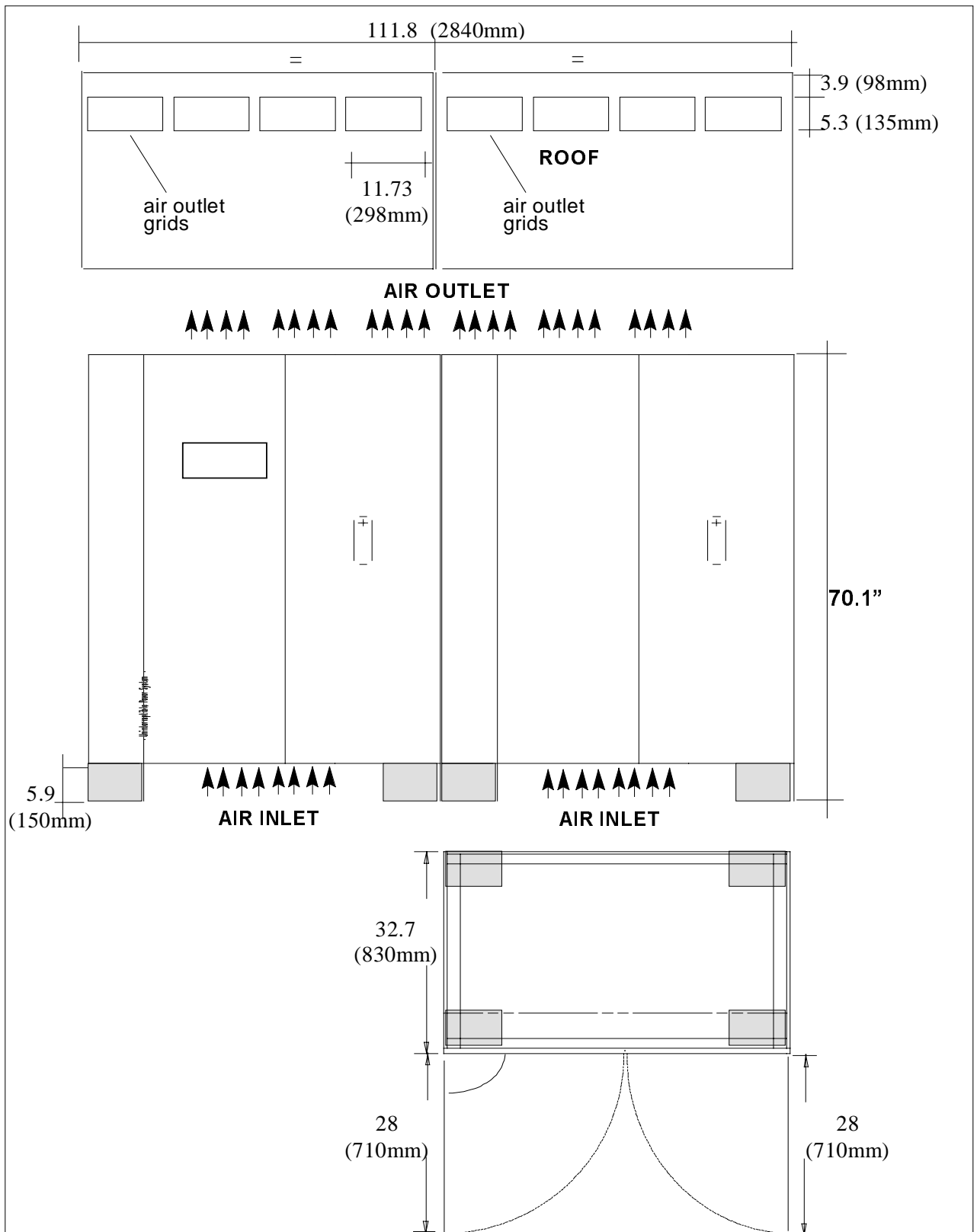

Figure C - Dimensions of 450 and 500kVA UPS in inches (and millimeters)

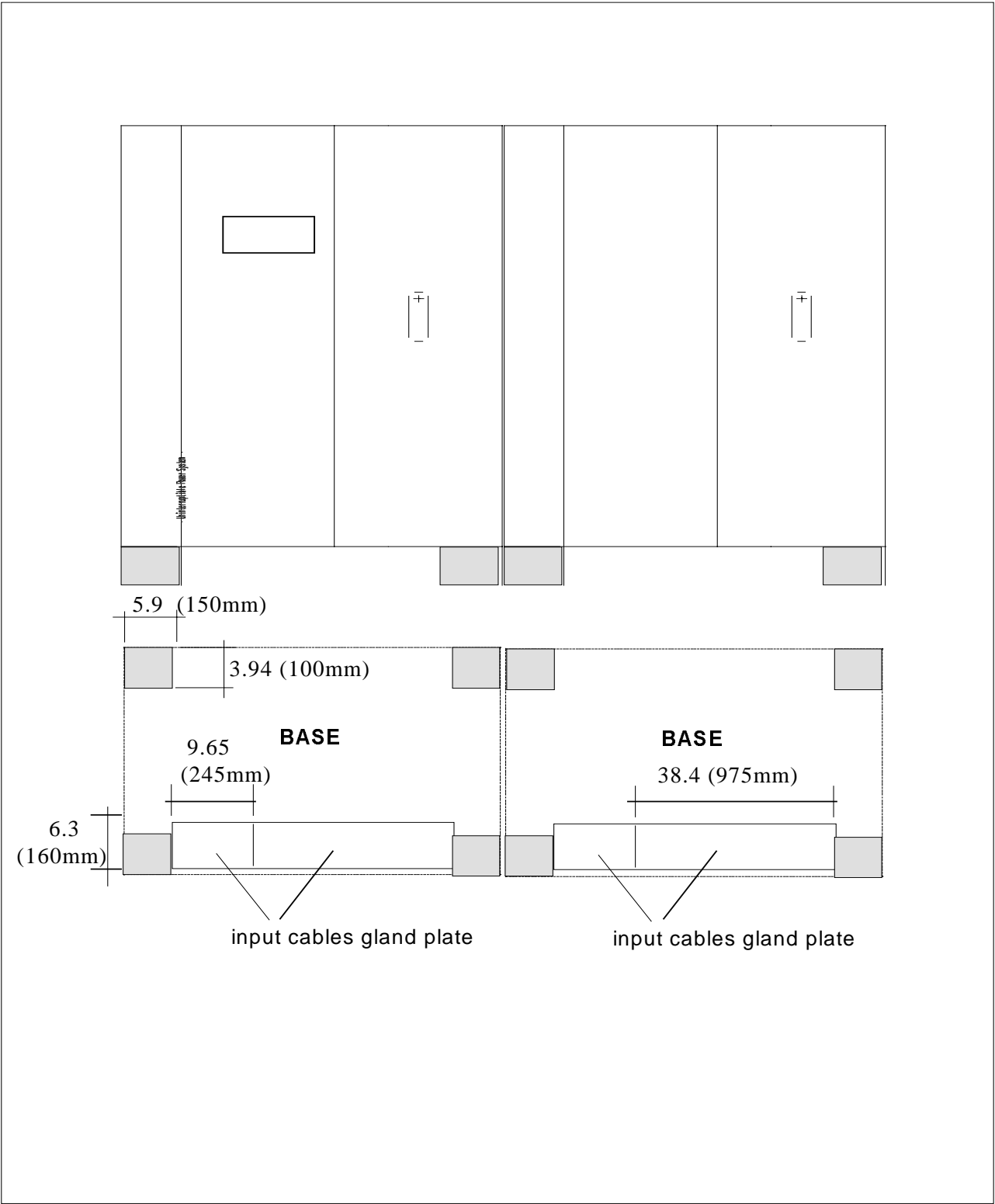

Figure D - Dimensions of 450 and 500 kVA UPS in inches (and millimeters)

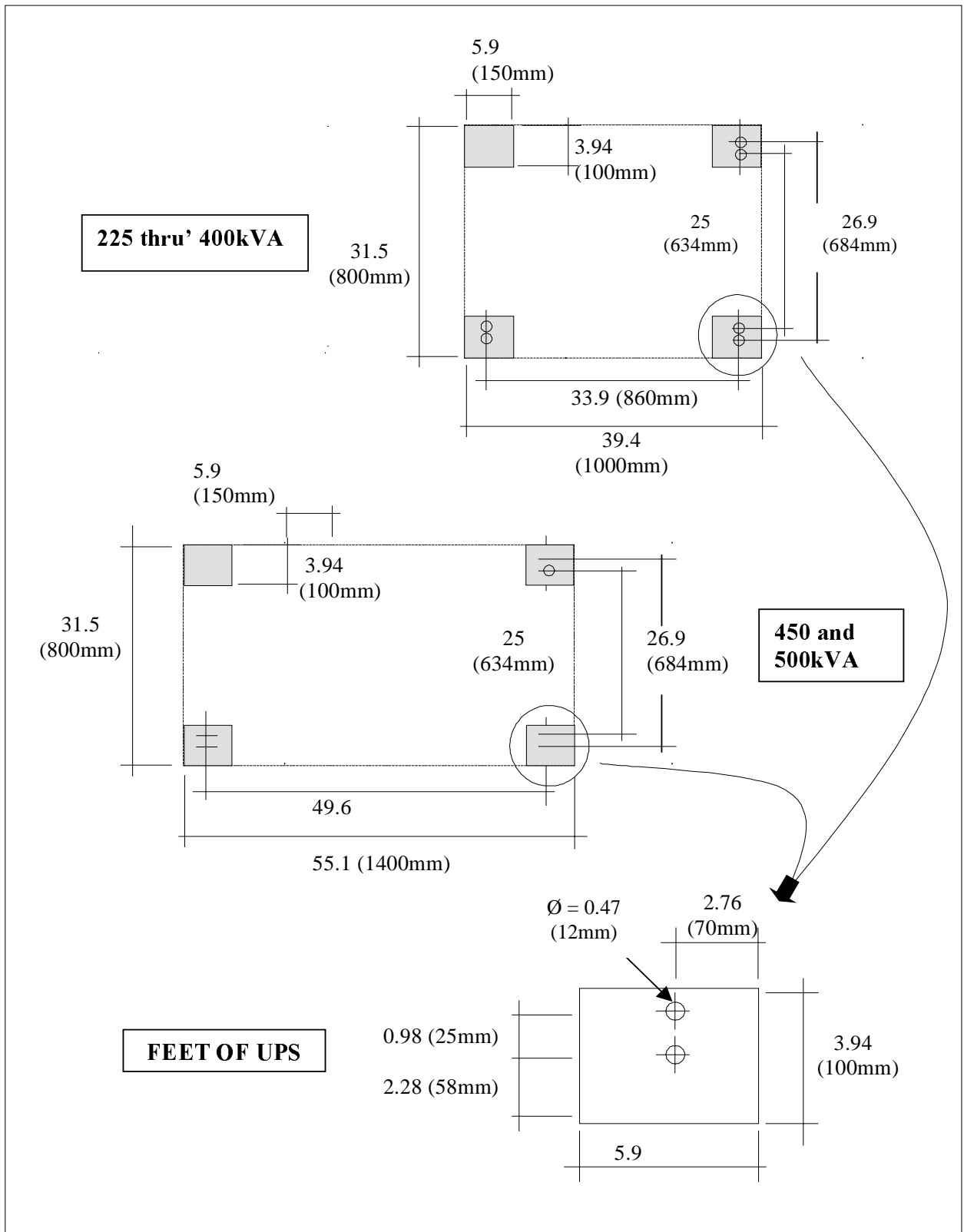

Figure E - Cubicle footprint all dimensions in inches (and millimeters)

3.2 Single UPS electrical connections

The diagram below shows single UPS electrical power connections, EDP90 series:

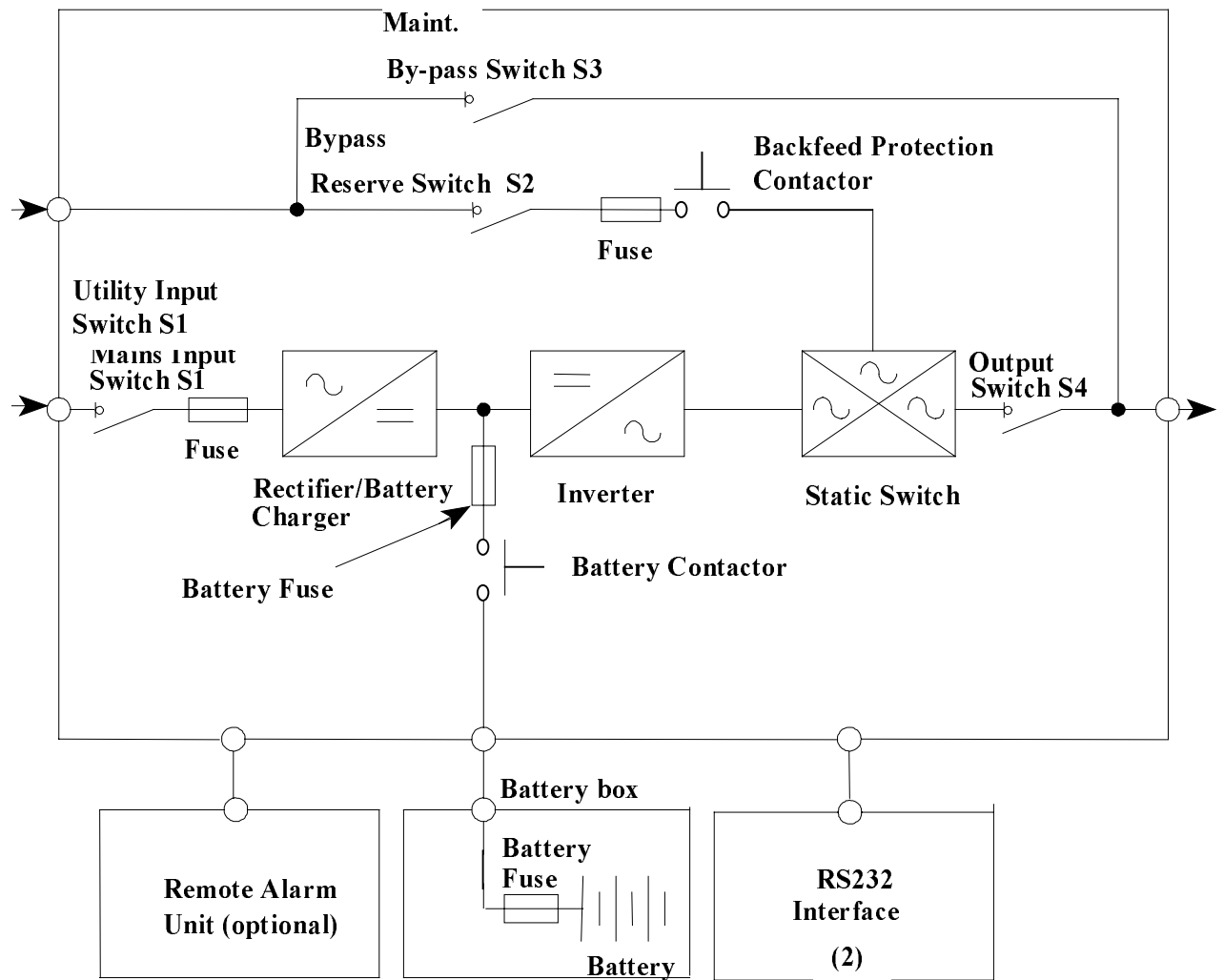

Figure F - Single UPS connections

3.3 Distributed parallel system electrical connections

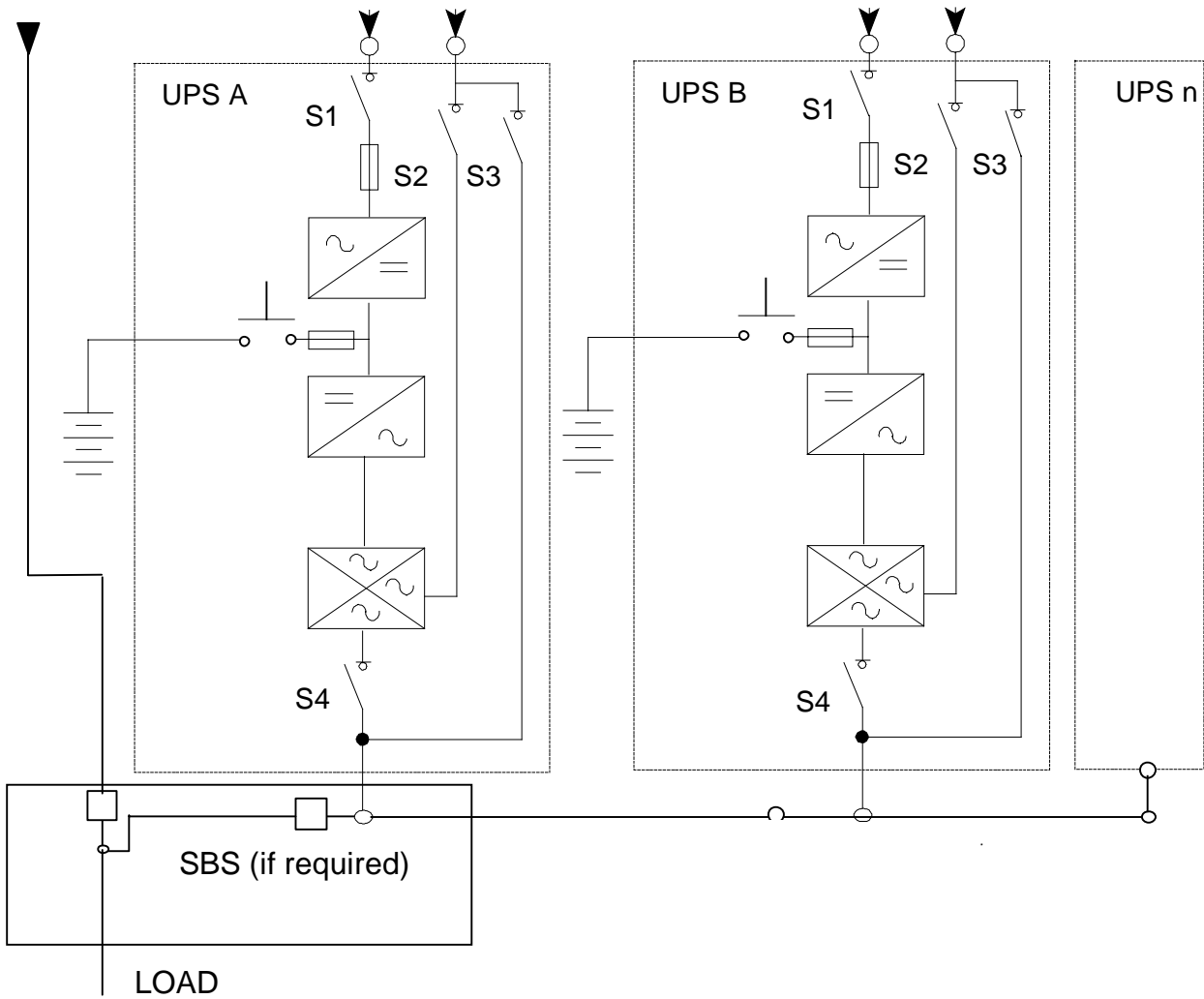

Figure G - Distributed parallel system electrical connections

Note: In a distributed parallel system when the first bypass maintenance switch - S3 - is closed the entire load current flows through this switch, the consequent risk of overload can be avoided by installing a correctly current-rated external System Bypass Switch (SBS).

3.4 Protection devices

The electrical and electronic protections inside the UPS have the single function of protecting the subassemblies and devices inside the units themselves.

For this reason, external devices for protection of cables and loads should be fitted up and down line of the system, and sized as follows.

The devices should be circuit breakers or fuses and isolating switches, sized for the currents as indicated below, they should be fitted as close as possible to the supply source, and clearly marked:

ISOLATE THE UNINTERRUPTIBLE POWER SYSTEM (UPS) PRIOR TO OPERATIONS ON THIS CIRCUIT

Protections on Utility input:

These should be capable of protecting the Utility AC Utility supply system up-line of the UPS, and should take into account the maximum current drain of each UPS as shown in the tables on pages 27 and 28.

Protections on Bypass input:

These should be capable of protecting the Bypass supply, taking into account the maximum power requirements as follows:

10 I_n for 5 cycles

7 I_n for 30 cycles

1.5 I_n for 1 minute

1.25 I_n for 10 minutes,

$$\text{where: } I_n = \frac{P_n}{\sqrt{3} * V_n}$$

P_n = rated power at output [kVA]

V_n = rated voltage at output [V]

Protections on battery input:

(required only if batteries are not fitted in cubicles beside the UPS cubicle)

These should be capable of protecting the battery against short-circuits, and should take into account the maximum power drain (in discharging 1.8V for cells), shown in the tables on page 27 and 28. These devices should be fitted as close as possible to the battery.

Protections on Output line:

As load(s) can be supplied through the Uninterruptible Power System from three sources, the protection system on the output line should take into account the ratings of the following supplies:

1) supply from UPS:

2 I_n for 10 milliseconds,

1.5 I_n for 1 minute

1.25 I_n for 10 minutes,

2) supply from Bypass static switch:

10 I_n for 5 cycles

7 I_n for 30 cycles

1.5 I_n for 1 minutes

1.25 I_n for 10 minutes,

3) supply through Maint. switch:

In this state, the Bypass input is directly connected to the output terminals, maximum current equals Bypass supply short-circuit current.

Protection should be rated for this short-circuit current and be able to operate in less than 10 milliseconds at a current equal to 2 I_n .

3.5 PE Connection

All cubicles (UPS, BATTERIES, etc.) must be connected to an earthing system complying with national safety regulations.

Cables (PE) connecting the cubicles to the earthing system must be sized according to national and local regulations.

3.6 NEUTRAL connections

The EDP90 Uninterruptible Power System does not modify the existing electrical system with regards to the neutral and earth connections.

As some loads cannot be used with all systems of neutral connection, check that all loads are supplied in the correct mode.

N.B.: Interruption of the Neutral Feed to the Bypass Supply will cause a change in the Earth-Neutral voltage and possible load malfunctions. Furthermore, operating the system without the Bypass Feed Neutral connected to the distribution system will isolate the system, with NO conventional earth fault protection.

In cases where the Bypass inputs of a distributed parallel system are supplied by a three-wire electrical system, the Neutrals of all units must be connected together even with no input/output neutral connection present.

3.7 GENERATOR power supply

The generator used with the Uninterruptible Power System is to have the following characteristics:

A) Electronic R.P.M. regulator;

B) Alternator with low reactance, able to accept the current harmonics generated by the UPS ($THD_1 = 10\%$). The supplier of the generator shall be informed of the harmonic value

3.8 Separate BYPASS

The double-input feed illustrated in figure F is supplied as equipment with the EDP90:

The separation of cables and protections raises UPS safety standards as well as improving continuity of supply to the critical load, thereby eliminating single point of failure up-line.

At the cost of reduced reliability, the two inputs can be linked, as shown in figure G:

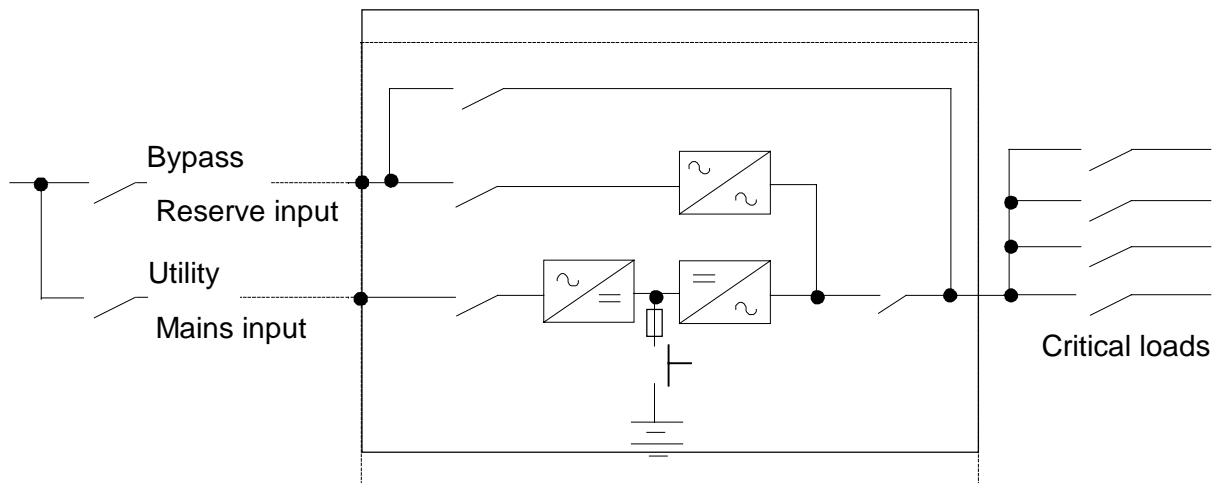

Figure H

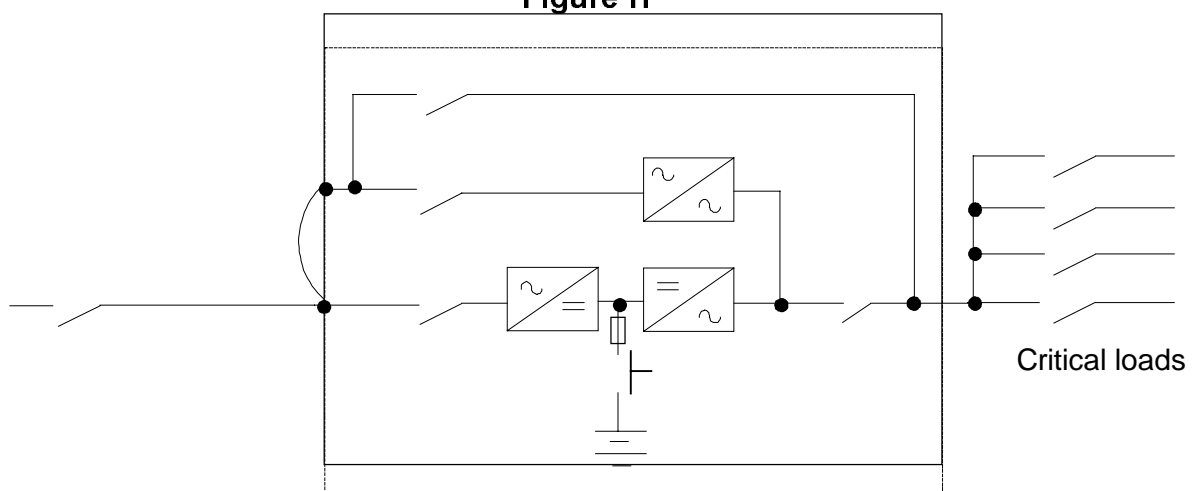

Figure I

3.9 Non linear LOADS

Most loads supplied by the UPS include switching power supplies and operate from a 50 or 60Hz AC line with capacitive input filter, as shown in figure H.

This type of conversion draws current from the line only when the line voltage exceeds the filter capacitor voltage.

This means that the input current only flows for a short period near the peak of the input voltage wave form, therefore causing the current to flow as a series of short pulses, rather than a smooth sinusoidal current normally generated by a linear load.

In this situation where only single-phase, non-linear loads are connected to a 3 phase supply, there will be no compensation or neutralisation in the neutral conductor as there would be in the case of linear sinusoidal currents.

In the case described above, the neutral current could be up to 1.7 times the line current, leading to heavy overloading of the neutral conductor as well as excessive voltage drop.

If the real neutral current cannot be measured, oversize the neutral conductor by 170%.

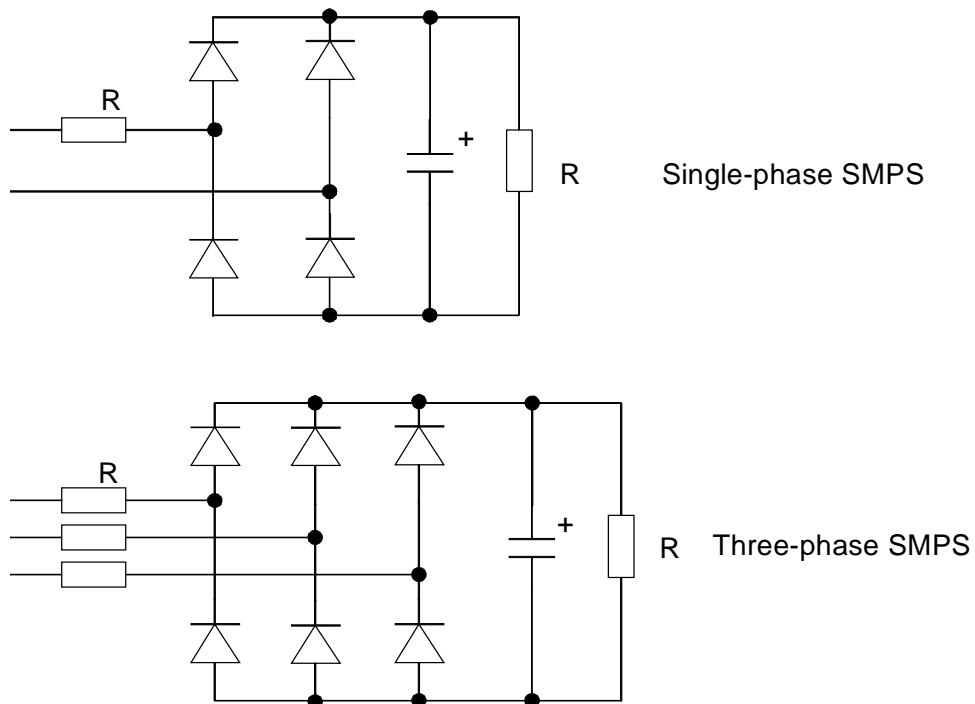

Figure J

3.10 Battery commissioning and installation

SAFETY

- Ensure that all switches are turned OFF before installing batteries; if switches are not turned to OFF, the equipment and battery may be damaged. For safety reasons, also disconnect the battery connectors before removing fuse F1 and F2 (behind the hinged panel) to interrupt the battery circuit.
- Stand on a rubber mat and use insulated rods.
- Remove rings, watches, pens and all other personal effects which might cause a short circuit when operating on the battery. Batteries are live at all times; short circuits can melt metals, and cause injury, damage or fire.
- DO NOT SMOKE or use open flames. Avoid creating arcs or sparks when working on equipment. Do not wear clothing which may generate static electricity.
- Sealed lead batteries contain sulphuric acid. If a battery is damaged, leaked acid will cause skin burns on contact and will attack metal, paint and fabrics. Wash any contaminated parts with abundant clean water. Always wear rubber gloves when handling damaged batteries.
- Battery life will be reduced if the temperature rises above the 25°C (77°F) average. Generally, battery life will be halved by a 8°C (14°F) increase above 77°F (25°C). Ambient temperature should range between 15°C (59°F) and 25°C (77°F).

4. CONNECTIONS

4.1 Recommended cable sizes

Refer to Selection of Recommended UPS Cable Sizes - Table 3 - and Power Connections Data - Table 4.

- 1) It is recommended that the external cables and protection be selected for the highest rated unit of the model in use.
- 2) Bypass (or Utility) input and output Neutral cable size should be greater than that of the line cables in order to supply non-linear loads having a Crest Factor of up to 3:1 (i.e. where neutral current = 1.7 x line current). If non-linear loads are not to be supplied from the Installation, the Neutral may be of the same size as the line cable.
- 3) Recommended AC input overcurrent protection represents 125% of nominal full load current (continuous) plus the short duration input current (non-continuous) for battery recharging per NEC 220-10b.
- 4) UPS output cables should be routed in separate conduits from input cables.
- 5) Grounding conductors are sized according to NEC 250-95.
- 6) Cable sizes are based upon NEC 310-16 for Copper conductors rated at 75°C (167°F) at an ambient temperature of 40°C (104°F).

Recommended sizes only. Be sure to observe the codes which apply to your installation.

TABLE 3. SELECTION OF RECOMMENDED UPS CABLE SIZES.

	EDP90 USA 225kVA	EDP90 USA 250kVA	EDP90 USA 300kVA	EDP90 USA 350kVA	EDP90 USA 400kVA	EDP90 USA 450kVA	EDP90 USA 500kVA
UTILITY INPUT	2 wires per connector MCM 250	2 wires per connector MCM 300	2 wires per connector MCM 500	3 wires per connector MCM 300	3 wires per connector MCM 350	3 wires per connector MCM 500	3 wires per connector MCM 500
BYPASS INPUT	2 wires AWG 3/0 (or 1 x MCM 500)	2 wires AWG 4/0	2 wires MCM 250	2 wires MCM 350	2 wires MCM 400	2 wires MCM 500	3 wires MCM 300
OUTPUT @ 480V	2 wires AWG 3/0 (or 1 x MCM 500)	2 wires AWG 4/0	2 wires MCM 250	2 wires MCM 350	2 wires MCM 400	2 wires MCM 500	3 wires MCM 300
BATTERY (AUTONOMY 30')	2 wires MCM 250	2 wires MCM 300	2 wires MCM 400	3 wires MCM 300	3 wires MCM 350	3 wires MCM 400	3 wires MCM 500
EARTH CABLE	AWG2	AWG2	AWG1	AWG1/0	AWG1/0	AWG2/0	AWG2/0

For autonomy > 30' multiply Max. battery current by 1.06 and resize cables accordingly.
If the length of the cables causes a voltage drop > 3%, use a larger wire size.

4.2 Data for UPS power connections

TABLE 4. POWER CONNECTIONS DATA

UPS TYPE	Utility Input		Output	Bypass Input	
	Max. Rated Current (A)	Protection Device (A)	Nominal Current (A)	Nominal Current (A)	Protection Device (A)
225kVA	368	500	271	271	350
250kVA	408	500	301	301	400
300kVA	490	600	361	361	450
350kVA	569	700	421	421	500
400kVA	650	800	481	481	600
450kVA	738	900	541	541	700
500kVA	820	1000	601	601	800

4.3 225 through 400kVA UPS connections

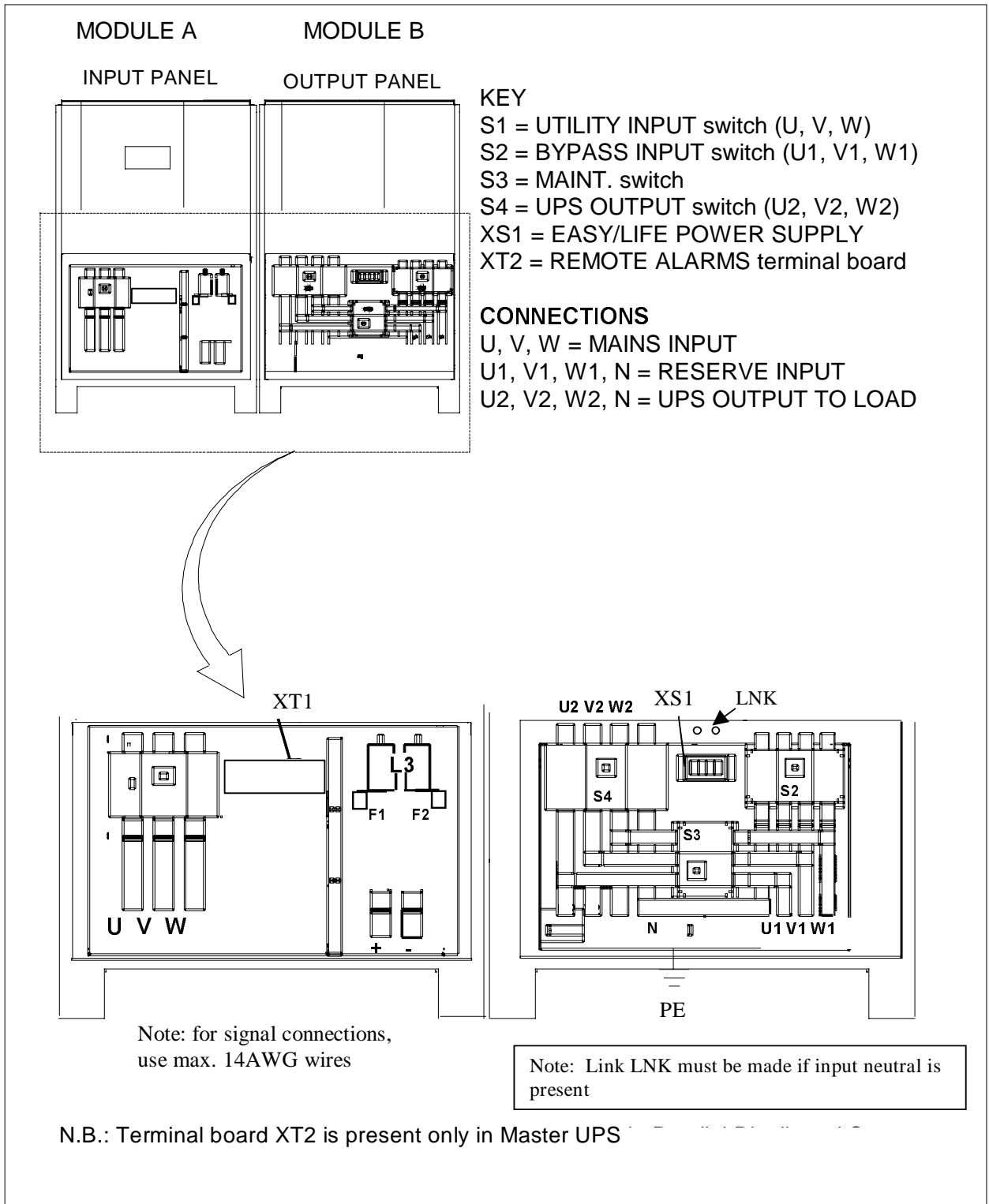

Figure K – 225 through 400kVA UPS connections

4.4 225 through 400kVA UPS power and signal connections

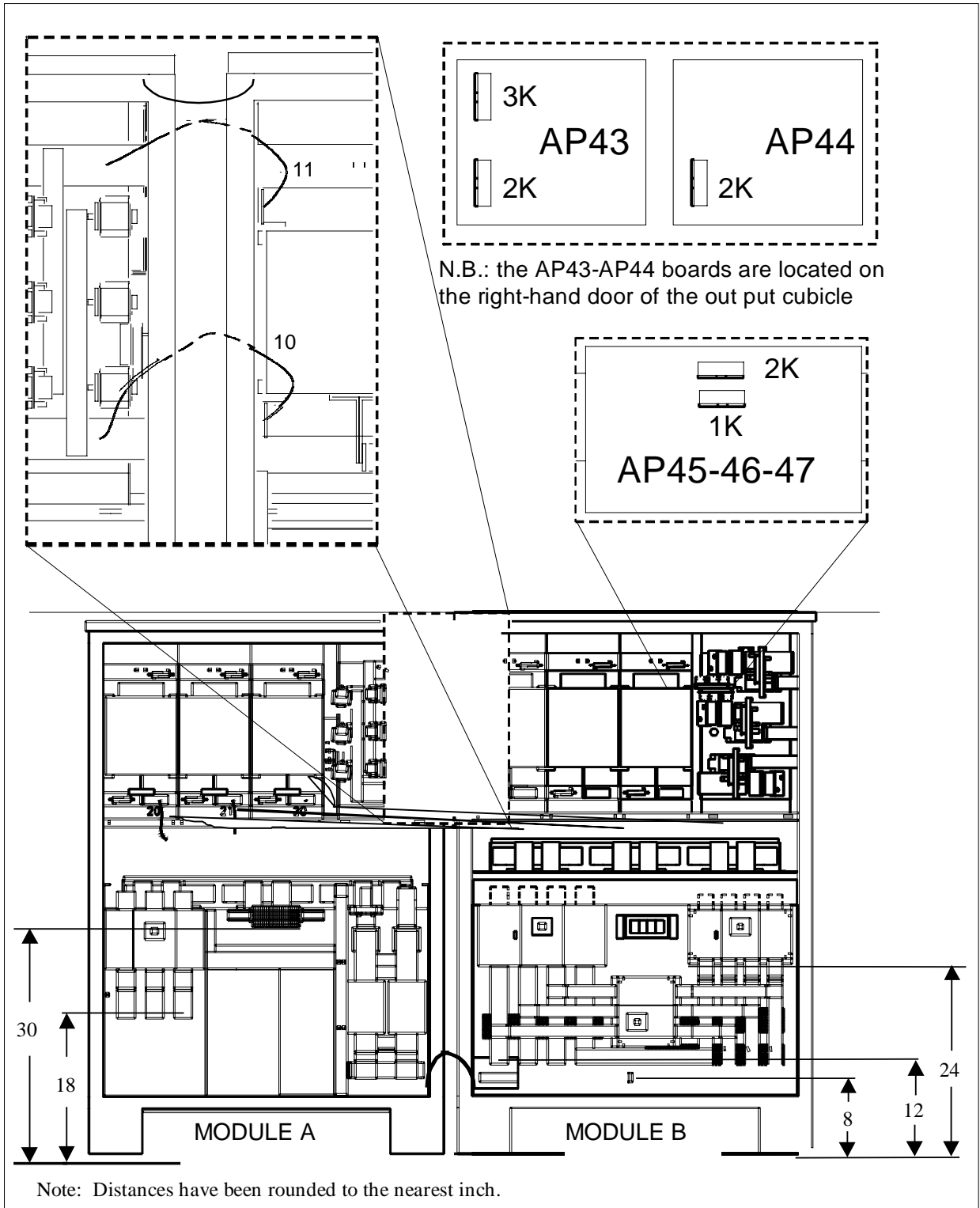

Figure L- Power and signal connections between 225 through 400kVA UPS cubicles

4.5 450 and 500kVA UPS power and signal connections

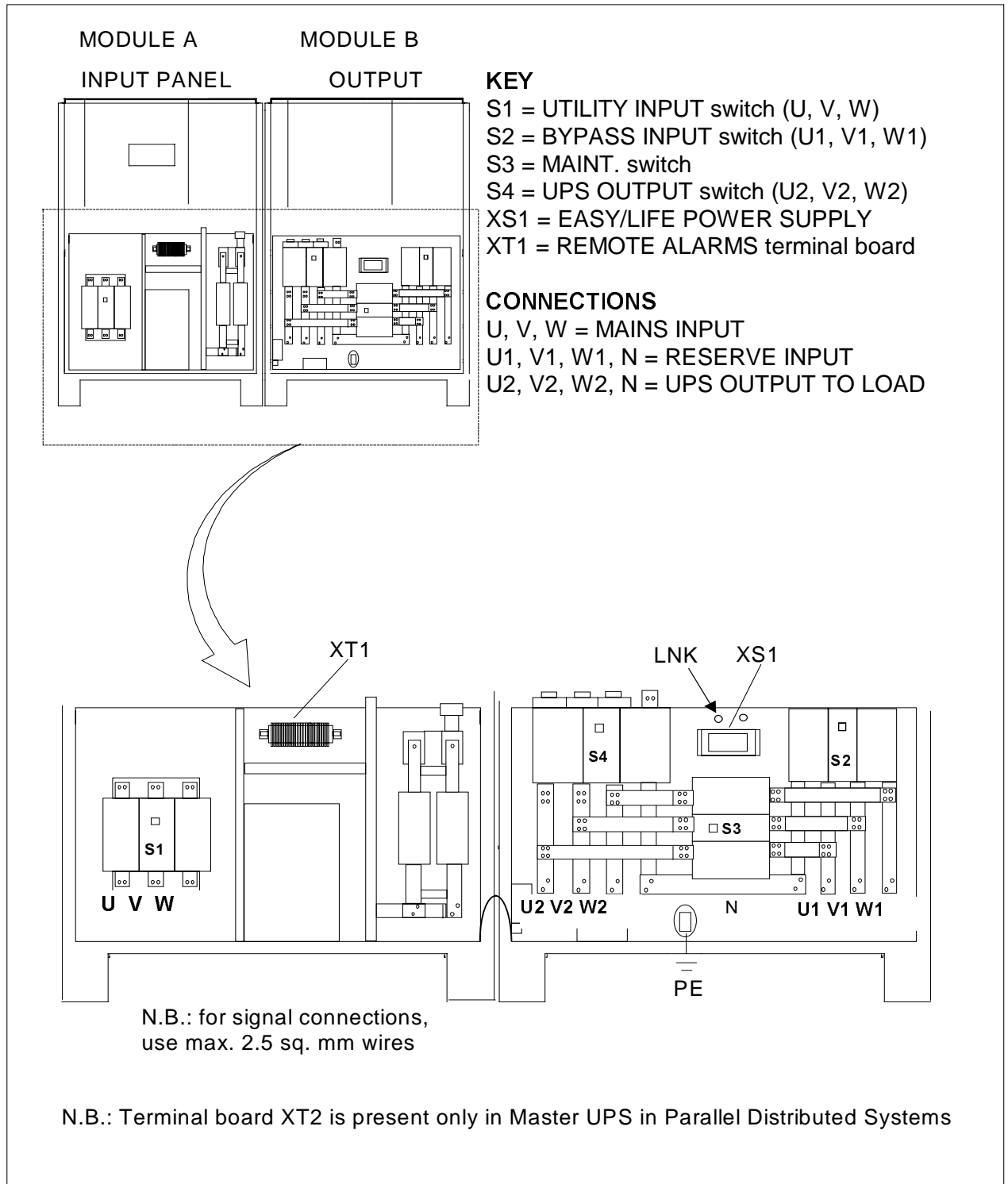

Figure M - Power and signal inter-connections 450 and 500kVA UPS cubicles

4.6 450 and 500kVA UPS power and signal connections view

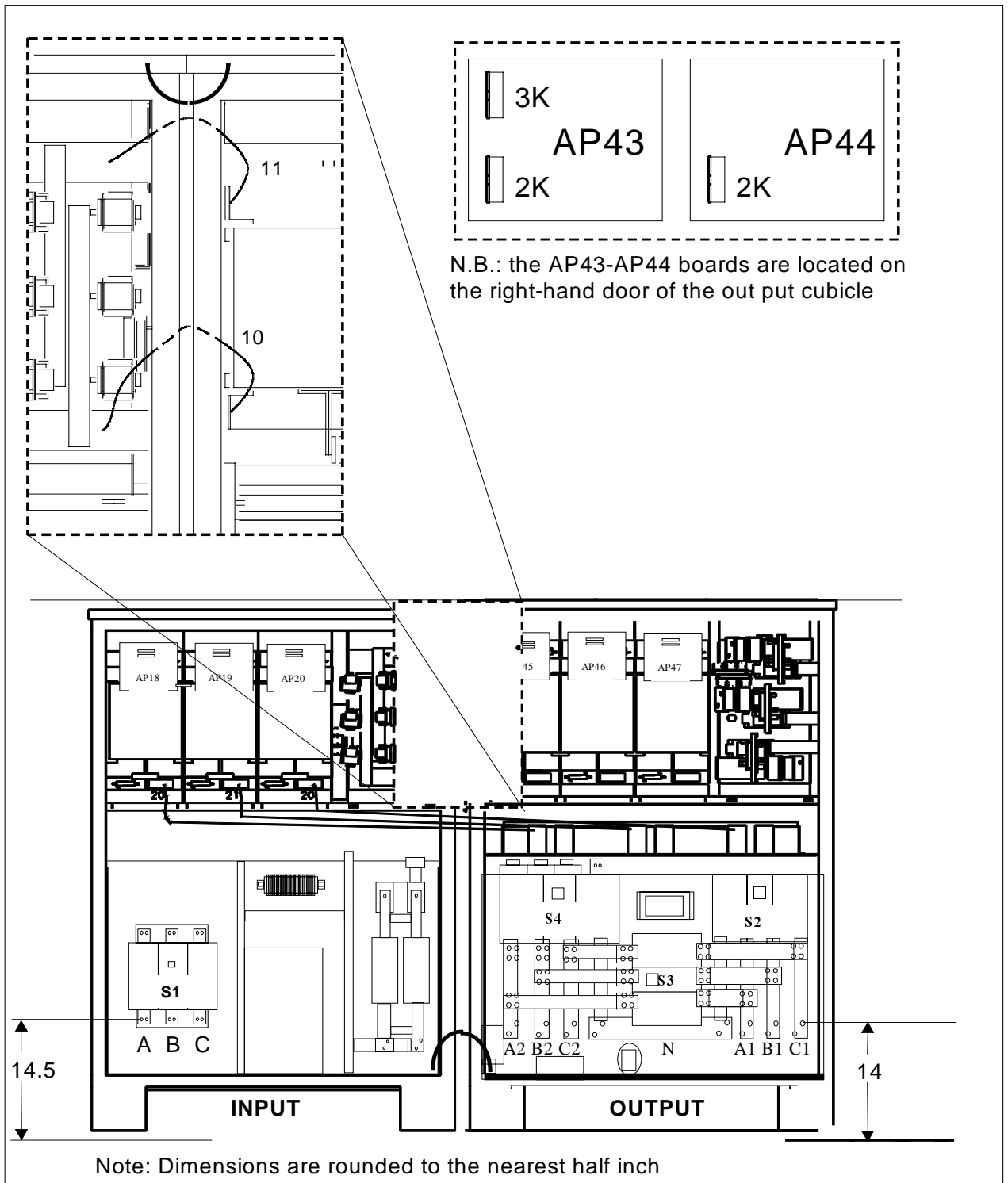
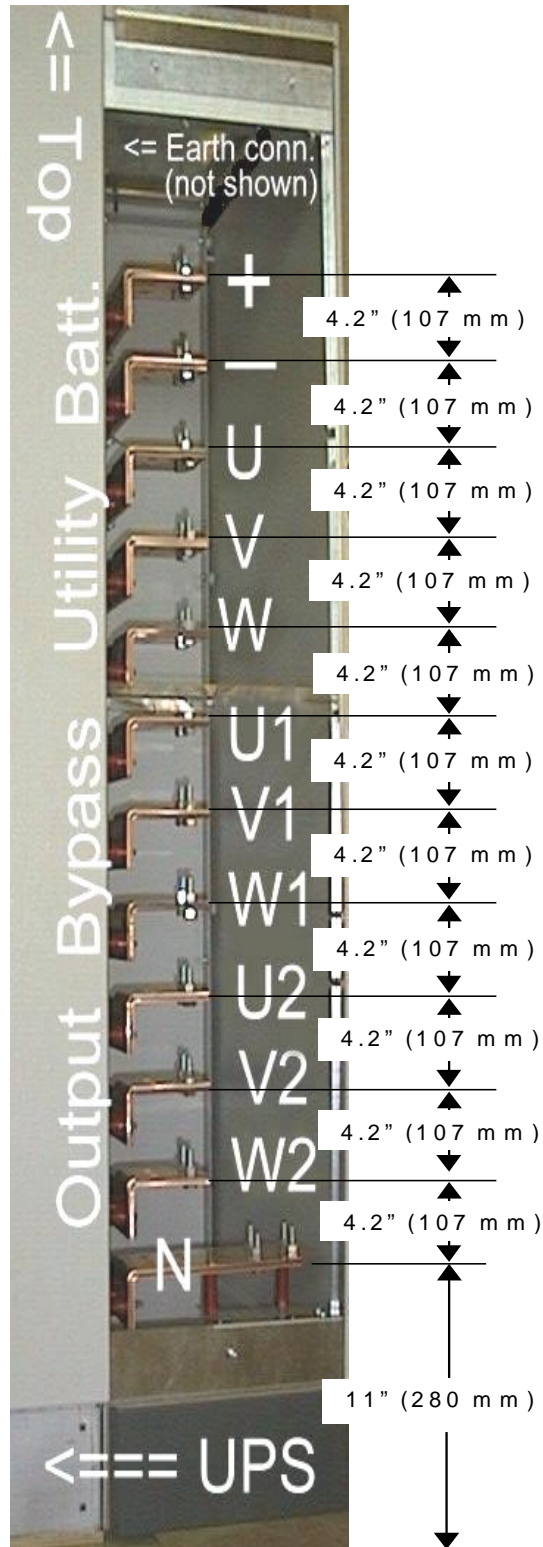

Figure N- Power and signal inter-connections 450 and 500kVA UPS cubicles

4.7 Customer Side Terminations – Output Cabinet

- 1) Allows Top/Bottom/Rear cable entry.
- 2) Front access only is required for connections in the field.
- 3) Up to four x MCM 500 cables with standard NEMA two hole lugs may be connected to each busbar.
- 4) Double sized neutral busbar
- 5) Complies with UL1778/NEC requirements on wire bending radius and spacing.
- 6) The width of the output cubicle is increased by 15 inches.



Power and signal connections for EDP90 225 through 500kVA

225 through 500kVA UPS units are supplied in 2 separate cubicles: After cubicles have been positioned side by side (see figures I thru' L), follow the connecting description below:

WIRING INSIDE INPUT CUBICLE

- a) Connect the earth wiring to the left-hand side of the switch box in the OUTPUT CUBICLE.
20 x M8 screws for connection are already located in the mounting holes.
- b) Connect wire **20** to bar **A'**; wire **21** to bar **B'**; wire **22** to bar **C'** in the OUTPUT CUBICLE.
30 x M10 screws for connection are already located in the mounting holes.
- c) Connect wire **10** to bar **+**; wire **11** to bar **-** in the OUTPUT CUBICLE.
20 x M8 screws for connection are already located in the mounting holes.

WARNING: wires with the same number must be connected to the same point.

FLAT CABLES INSIDE THE INPUT CUBICLE

- a) Connect flat cables:
 - FLO9 to connector AP45 - 1 K
 - FLO12 to connector AP45 - 2K
 - FLO10 to connector AP46 - 1K
 - FLO13 to connector AP46 - 2K
 - FLO11 to connector AP47 - 1K
 - FLO14 to connector AP47 - 2K
 - FLO54 to connector AP44 - 2K
 - FLO44 to connector AP43 - 2K
 - FLO40 to connector AP43 - 3K

in OUTPUT CUBICLE.

- b) Join connector X22 to corresponding connector in OUTPUT CUBICLE.

CONNECTORS IN THE OUTPUT CUBICLE

- a) Join connector X20 to corresponding connector in INPUT CUBICLE.

N.B. Wires 20 - 21 - 22 shall pass under the middle height horizontal cross-bar between the two cabinets.

4.8 INDIVIDUAL UPS signal connection information

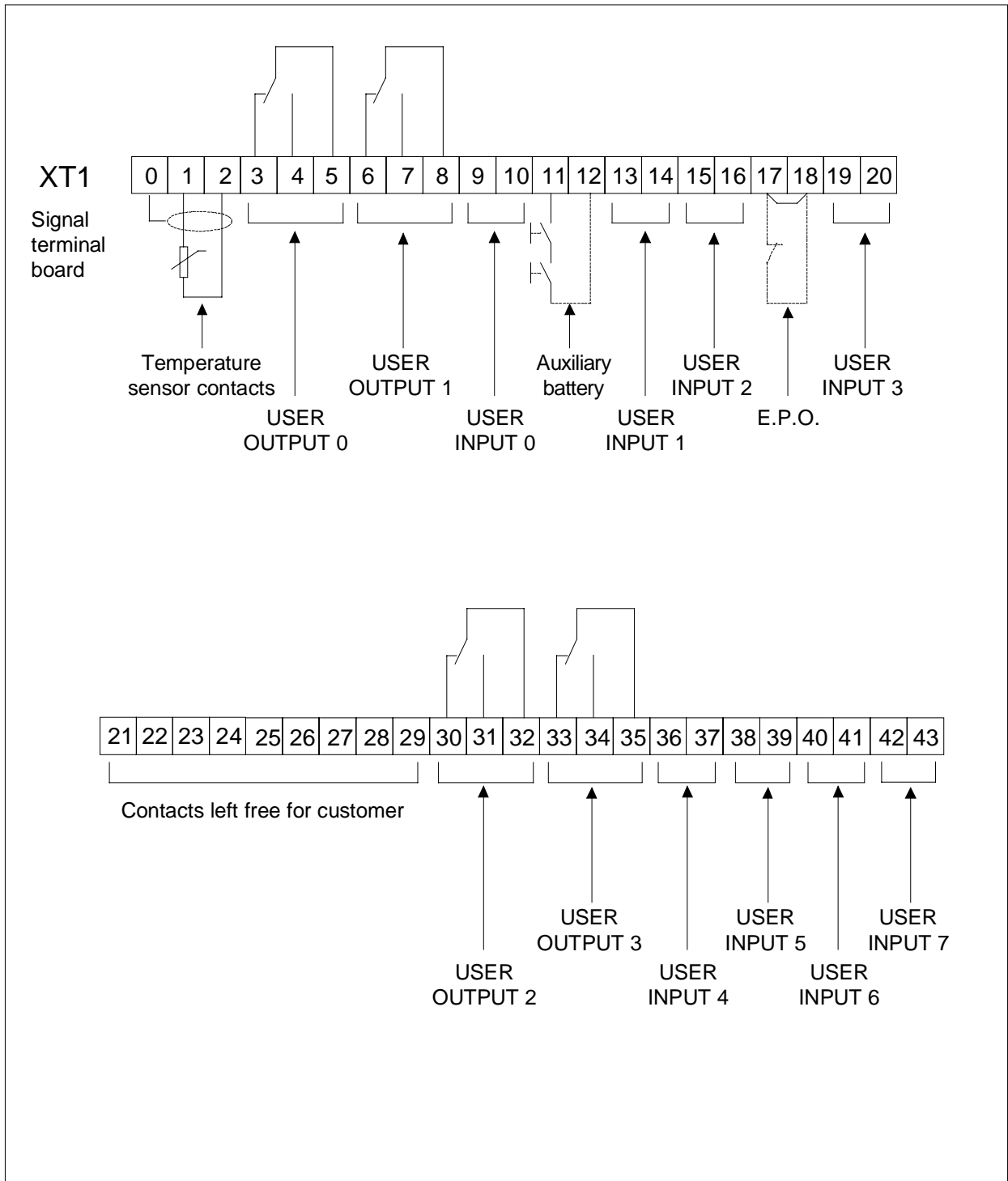

Figure O

4.9 Signal connection data: DISTRIBUTED parallel UPS

Signal terminal board connections for DISTRIBUTED PARALLEL SYSTEM without system Maint. switches (SBS).

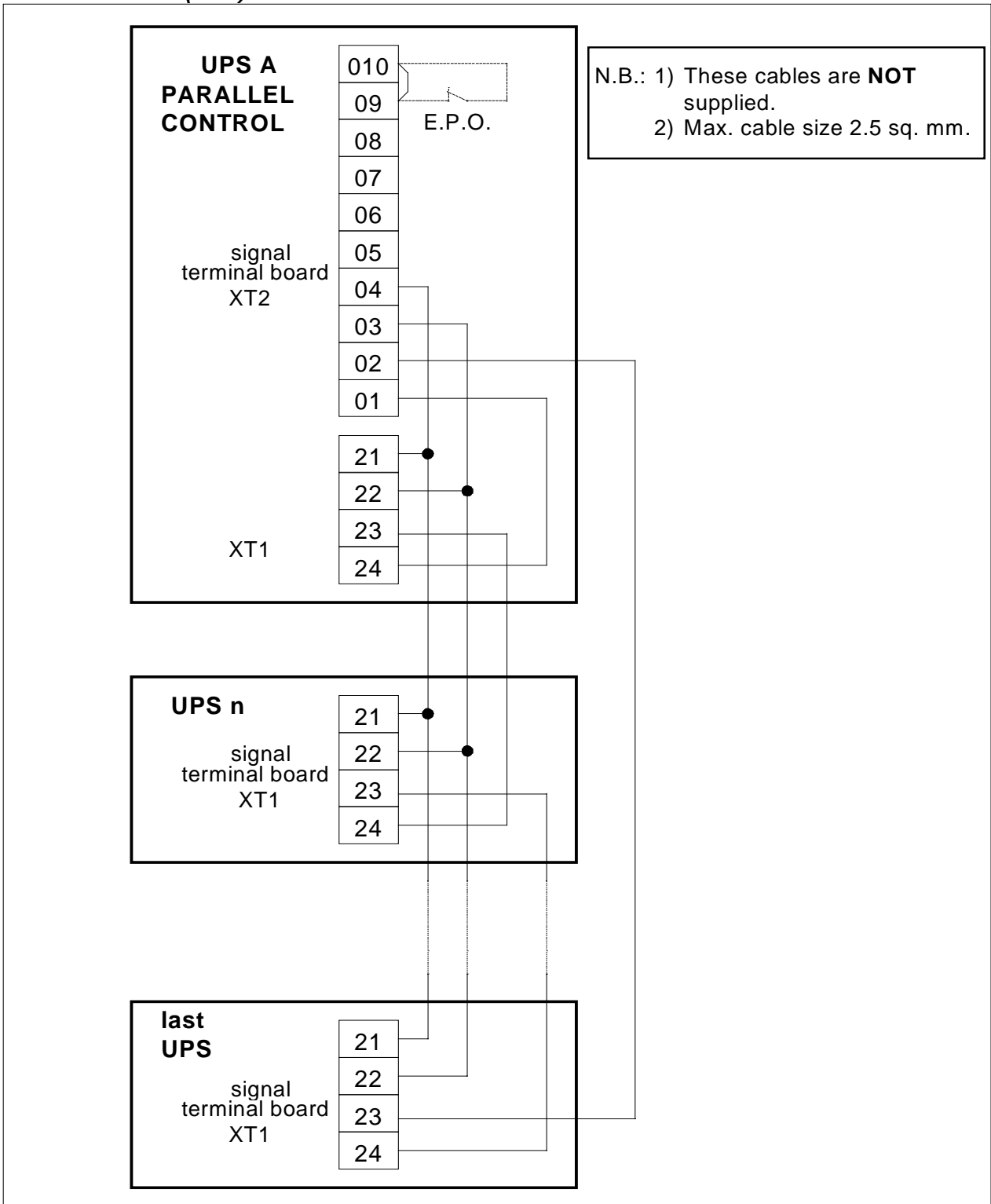

Figure P

Connection of flat cables:

UPS units are also connected for signals exchange; these wires are not supplied (max. wire size 2.5mm²).

In the installation area, cubicles may be positioned at the discretion of the customer, provided that the distance between UPS1 (PARALLEL CONTROL) and the other UPS units does not exceed 100' (30 m).

Do not install wires in the same passages or ducts used for power cables.

Signal wires are to be connected as per Figure Q below.

NOTE: The signal wires connected to the screw terminals 60PL through 65PL (AP29, UPS Parallel Control Boards) must be twisted couples. For each connector the couples are: wires 1 and 2, wires 3 and 4 through wires 23 and 24.

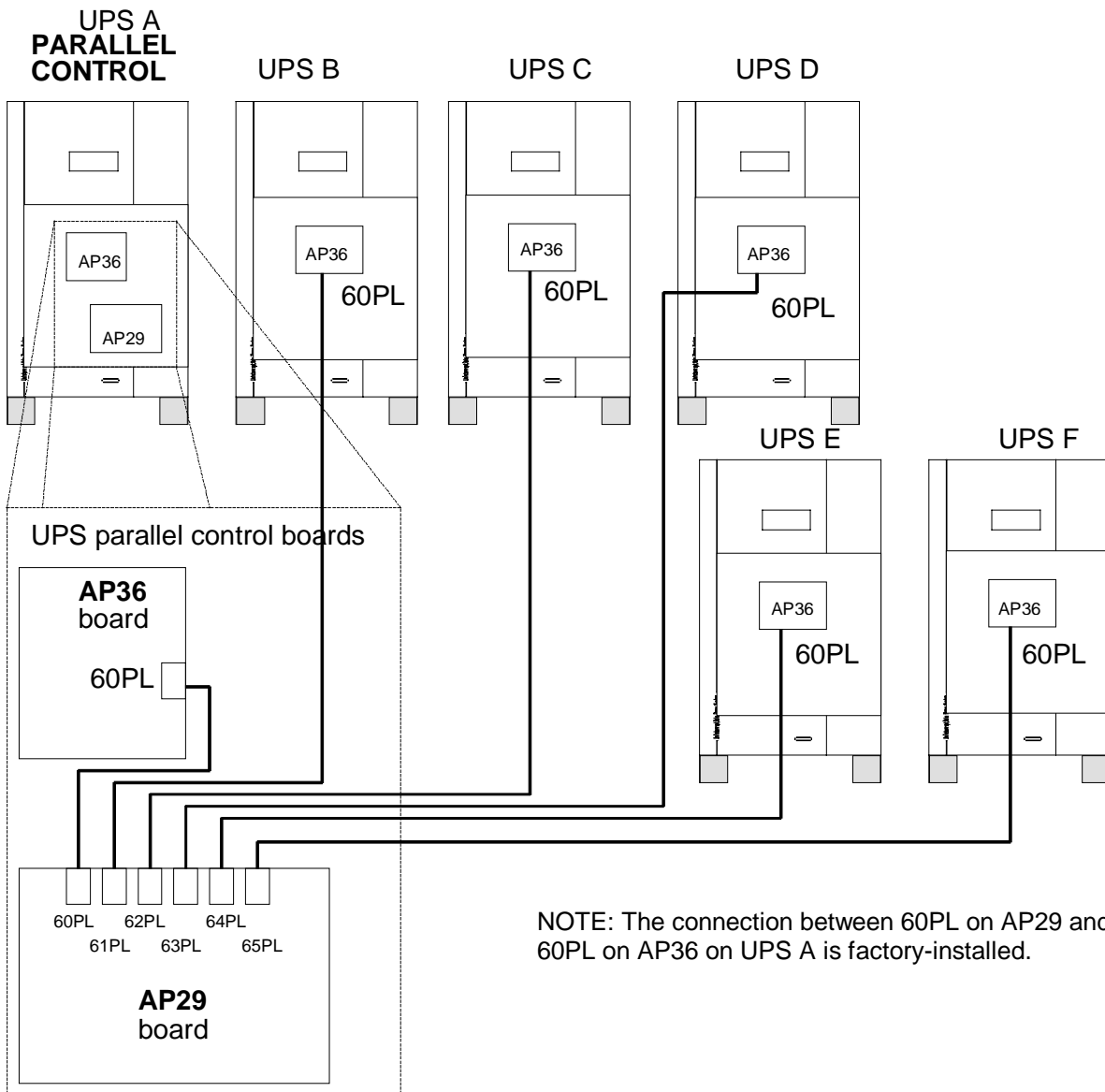

NOTE: The connection between 60PL on AP29 and 60PL on AP36 on UPS A is factory-installed.

Figure Q

SIGNAL CABLES INSTALLATION:

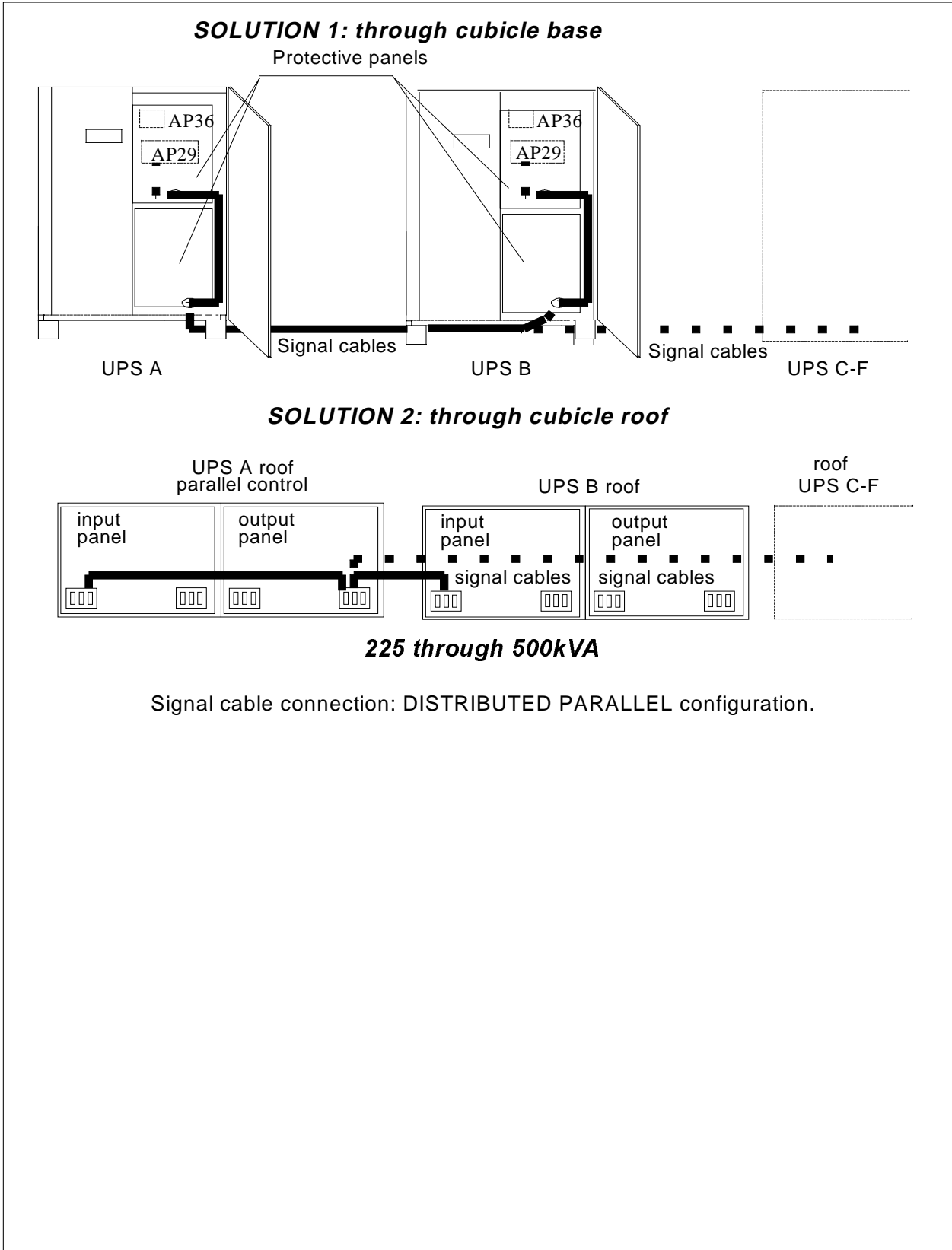

Figure R

5. Description of the system

5.1 Equipment

The EDP90 Uninterruptible Power System (UPS) totally isolates the load from the AC Utility supply, protecting it from voltage drops, spikes, transients, RFI and frequency variations.

In the event of total or partial AC Utility power failure, an internal alarm will sound. The EDP90 will continue, without interruption, to provide power to the load from the sealed battery. Duration will depend on battery capacity and output load.

The audible alarm and the indication of available autonomy allows the user to shut down the load without haste. When the AC Utility supply is restored, the EDP90 automatically recharges the batteries, ready for any power failure emergency.

The microprocessor display panel gives access to extremely detailed information regarding the status of supply and the EDP90. For further information, consult this manual.

The block diagram (fig. Q) shows the main features of the EDP90 UPS. The AC three-phase supply is rectified to provide direct current to maintain the battery charge and also to supply energy to the Inverter . This component converts continuous voltage into AC three-phase voltage.

The load may be powered from two sources: the Inverter and the Bypass input. The Inverter is the preferred source, through a "static switch". This allows inputs to be supplied from independent three-phase sources, thereby increasing system reliability.

In order for the Bypass input to be a real alternative source (though with lower reliability standards), the Inverter synchronizes its output frequency with the Bypass supply frequency. If the Bypass supply frequency is out of the limits, the Inverter ceases synchronization with Bypass frequency, operating with its own reference control to stabilize frequency output. This feature, in conjunction with the static switch, provides a continuous, reliable load power supply.

Maintenance and checking can be performed on the EDP90 UPS without interrupting output, by simply switching the load from the Bypass supply to the Maint. circuit. This operation should only be carried out by a Chloride service engineer or by Chloride-trained personnel.

5.2 Functions

RECTIFIER/BATTERY CHARGER

The rectifier-battery charger converts the alternating voltage of the Utility supply to direct voltage, thereby maintaining the battery in an optimum charge state and supplying the inverter.

BATTERY

The battery is an energy Bypass used by the inverter and the load in the event of Utility power failure.

INVERTER

The inverter converts the direct voltage from the rectifier or the battery into a three-phase sinusoidal alternating voltage for the external supply.

ELECTRONIC STATIC SWITCH

The functions of the electronic static switch is to choose one of the two sources of alternating voltage and to supply it to the external load. The two sources of voltage supplied to the static switch are the output of the inverter and the Bypass supply. In normal working conditions, the static switch supplies the load from the inverter.

SWITCHES

The switches system permits UPS maintenance and repair, without interruption of supply to the load.

5.3 Operation modes

STANDARD OPERATION

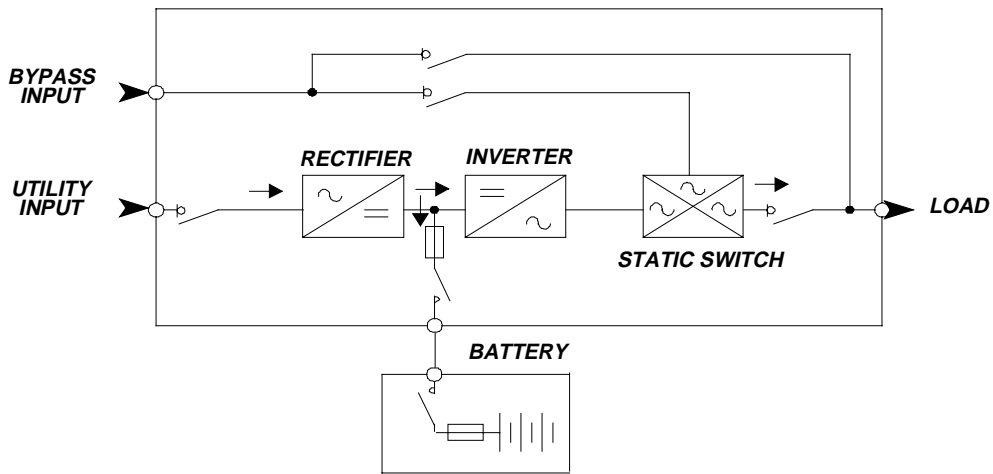

Figure S - Standard operation

During standard operation, the load is powered by the Utility through the rectifier and the inverter. The rectifier also supplies the current for recharging and maintaining the battery in a fully charged state.

UTILITY FAILURE

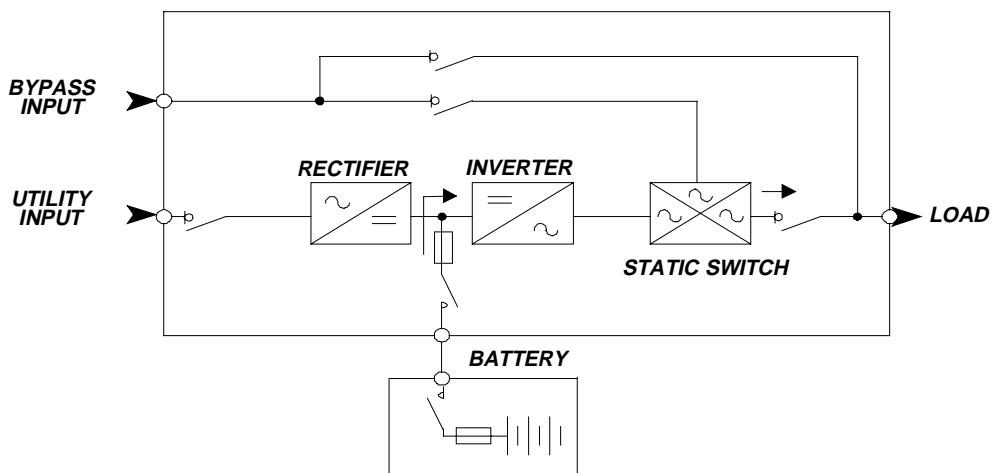

Figure T - Utility failure

When Utility voltage is outside the tolerances permitted, the battery supplies the inverter. This state will be indicated on the panel display on the UPS and the Remote Alarm Unit (optional). The duration of this time depends both on the capacity of the battery and on the size of the load. Autonomy can be extended by disconnecting loads of secondary importance. The alphanumeric display will show residual autonomy in all cases.

RESTORING UTILITY SUPPLY

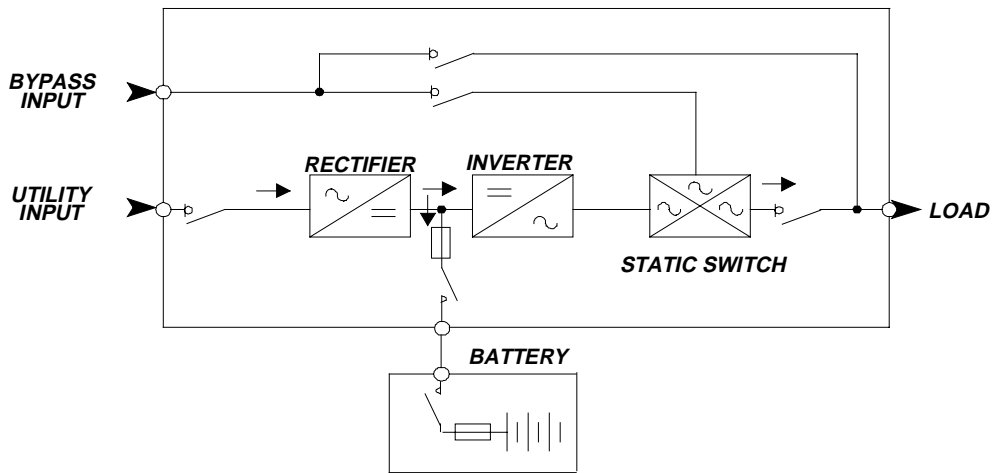

Figure U - Restoring Utility supply

When Utility supply returns within the permitted limits, the UPS automatically returns to the normal mode of operation (as described above), and the rectifier will commence recharging the battery. Any further Utility failure will result in reduced standby time until battery recharging has been completed.

TRANSFERRING THE LOAD ONTO BYPASS SUPPLY

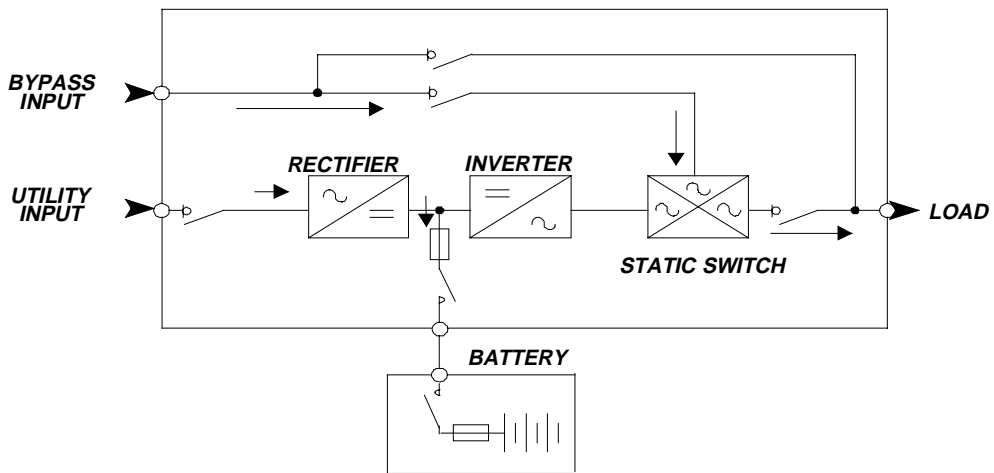

Figure V - Load transfer to Bypass supply

Transfer to the Bypass line is caused by two conditions:

- a) inverter stoppage
- b) overload

In both cases, the load is transferred on to the reserve without any interruption. If the overload is temporary, the system will re-transfer from Bypass to inverter as soon as the overload ceases. This allows for the initial start-up of loads with high inrush currents.

6. UPS CONTROLS

6.1 User controls

The user controls are located on the front panel (figure U).

Remove the front cover to gain access to the ON/OFF and Maint. switches.

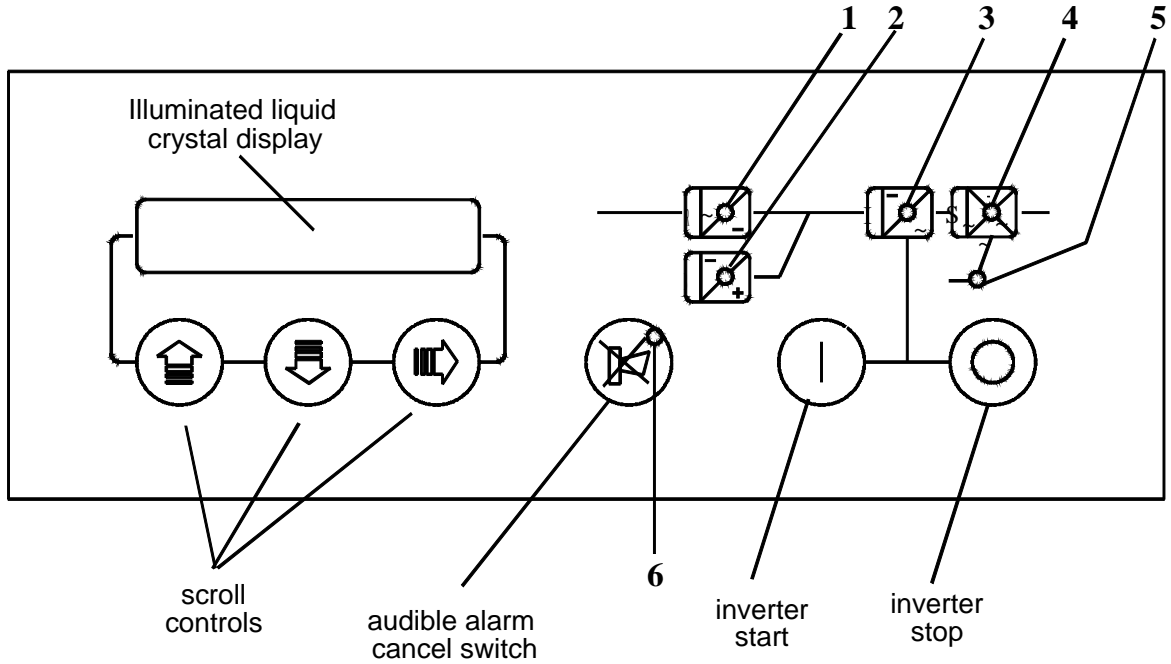

Figure W - Control panel

Display indicators

- | | |
|-----------------------------|--------------------------------|
| 1) Utility supply indicator | (green) - (flashing green) |
| 2) Battery indicator | (green) - (flashing green) |
| 3) Inverter indicator | (green) - (flashing green) |
| 4) Static switch indicator | (green) - (flashing green) |
| 5) Bypass supply indicator | (green) - (flashing green) |
| 6) Warning indicator | (off) - (red) - (flashing red) |

LEDs 1, 2, 3, 4, and 5 maintain constant green condition during normal conditions, and flash in an alarm situation. Red warning indicator 6 is off during normal UPS operating conditions, lights up with buzzer or during an alarm situation, flashes during a UPS alarm situation with buzzer off or when Power History is blocked.

6.2 Control panel

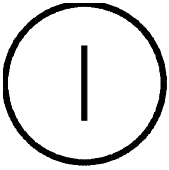

Inverter start

For turning on and resetting the inverter.

Normally used when starting the UPS.

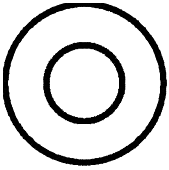

Inverter stop

The button incorporates a safety function to avoid accidental operation and therefore undesired shutdown of the inverter.

To stop the inverter in case of emergency, press the button for at least two seconds; the audible alarm will sound during this time, then the inverter will stop.

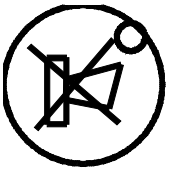

Audible alarm cancel switch

Cancels the audible alarm. When pressed, the red warning light starts flashing.

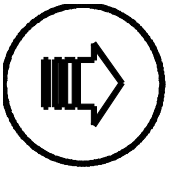

Page right control

Moves the page headings displayed on screen to the right.



Scroll up

Substitutes the message displayed with the previous one. Scrolling will stop at the top of the page.

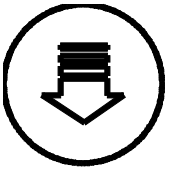

Scroll down

Substitutes the message displayed with the next. Scrolling will stop at the end of the page.

7. EDP90 Diagnostics for Single or Parallel UPS

Diagnostics is subdivided into several sections, each representing a functional element of the UPS (e.g. INVERTER, LOAD). Each block is broken down into 4 pages:

FIRST PAGE, stage page.

This PAGE displays the name of the stage (System, Rectifier, Battery, Inverter, Bypass, Load) and its general status.

Press  to access

SECOND PAGE, status page.

This PAGE displays the specific status of each stage.

Press  to access



THIRD PAGE, alarms page.

Stage alarms will be displayed only if at least one alarm is active.

Press  to access

FOURTH PAGE, measurements page.

All measurements relevant to the stage are displayed.

Use  or  to scroll through the information.

The figure below is intended to facilitate EDP90 diagnostics.

Introduction

The following pages will illustrate the messages available on the display. The symbols

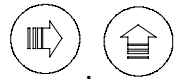

and  represent the three user pushbuttons below the display (fig. 30). The line attached to each arrow indicates the new message obtained by pressing the pushbutton.

N.B.:

Messages with () are for UPS Parallel configurations only.**

7.1 UPS messages normal condition

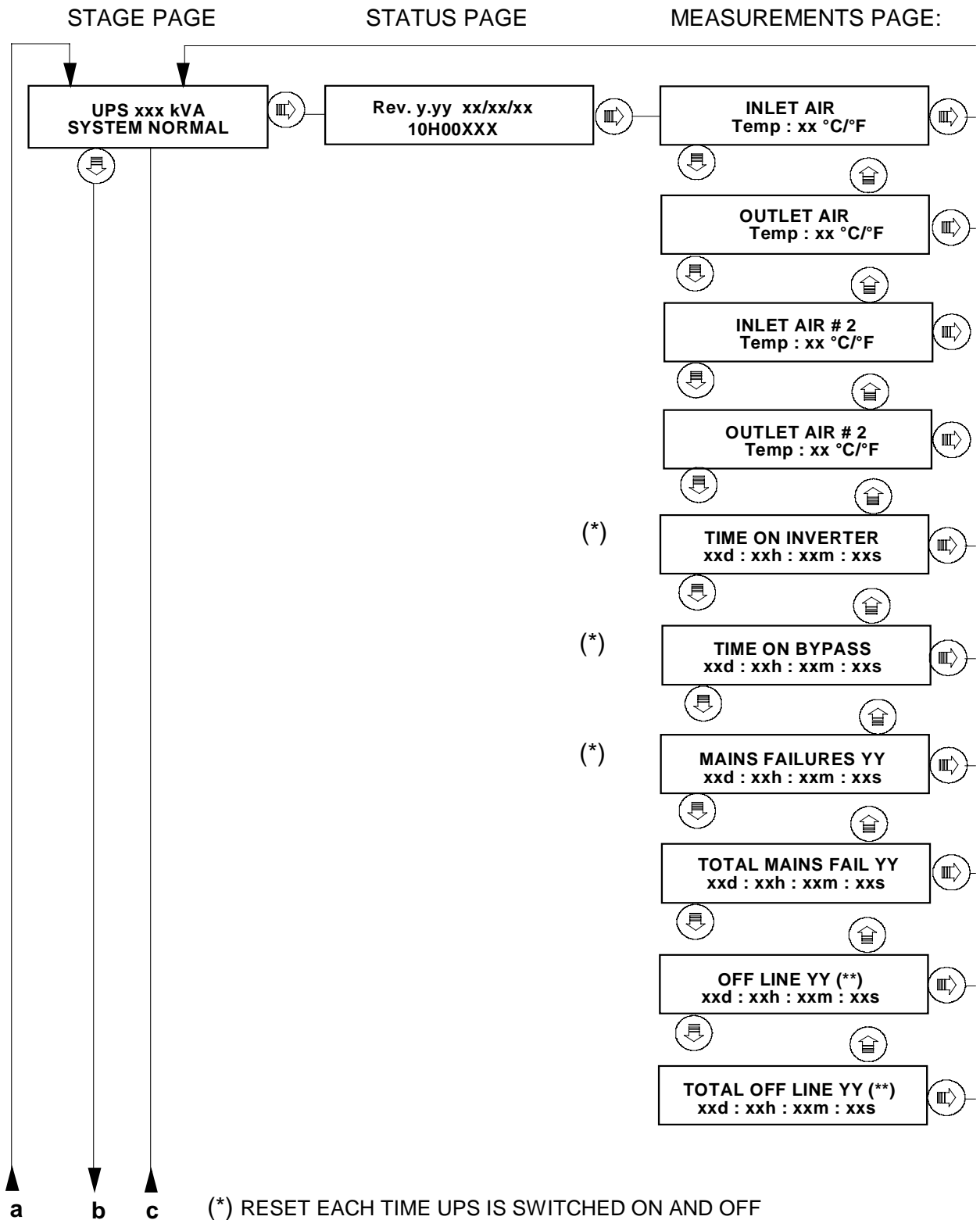

STAGE PAGE

STATUS PAGE

MEASUREMENTS PAGE:

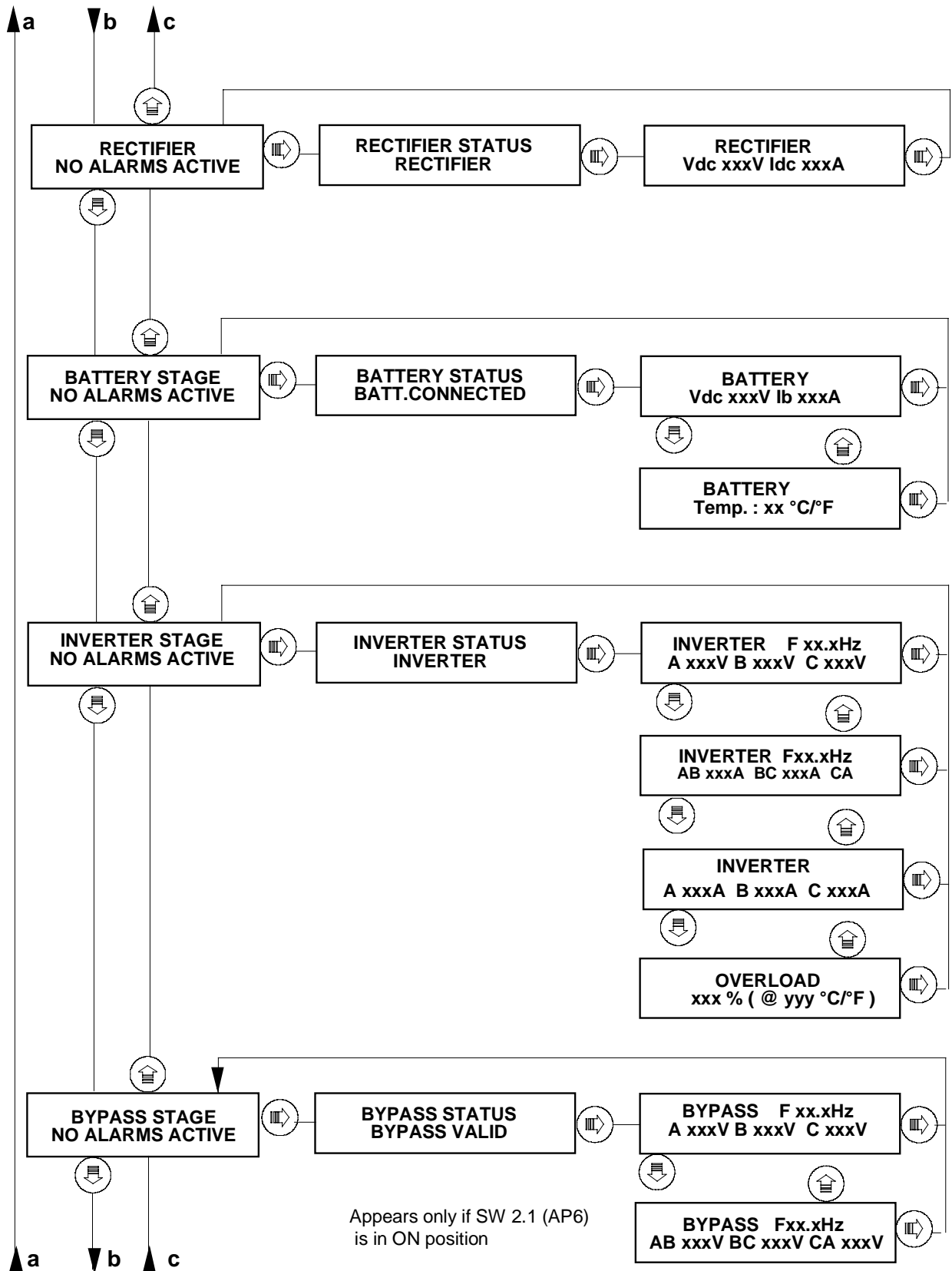

STAGE PAGE

STATUS PAGE

MEASUREMENTS PAGE:

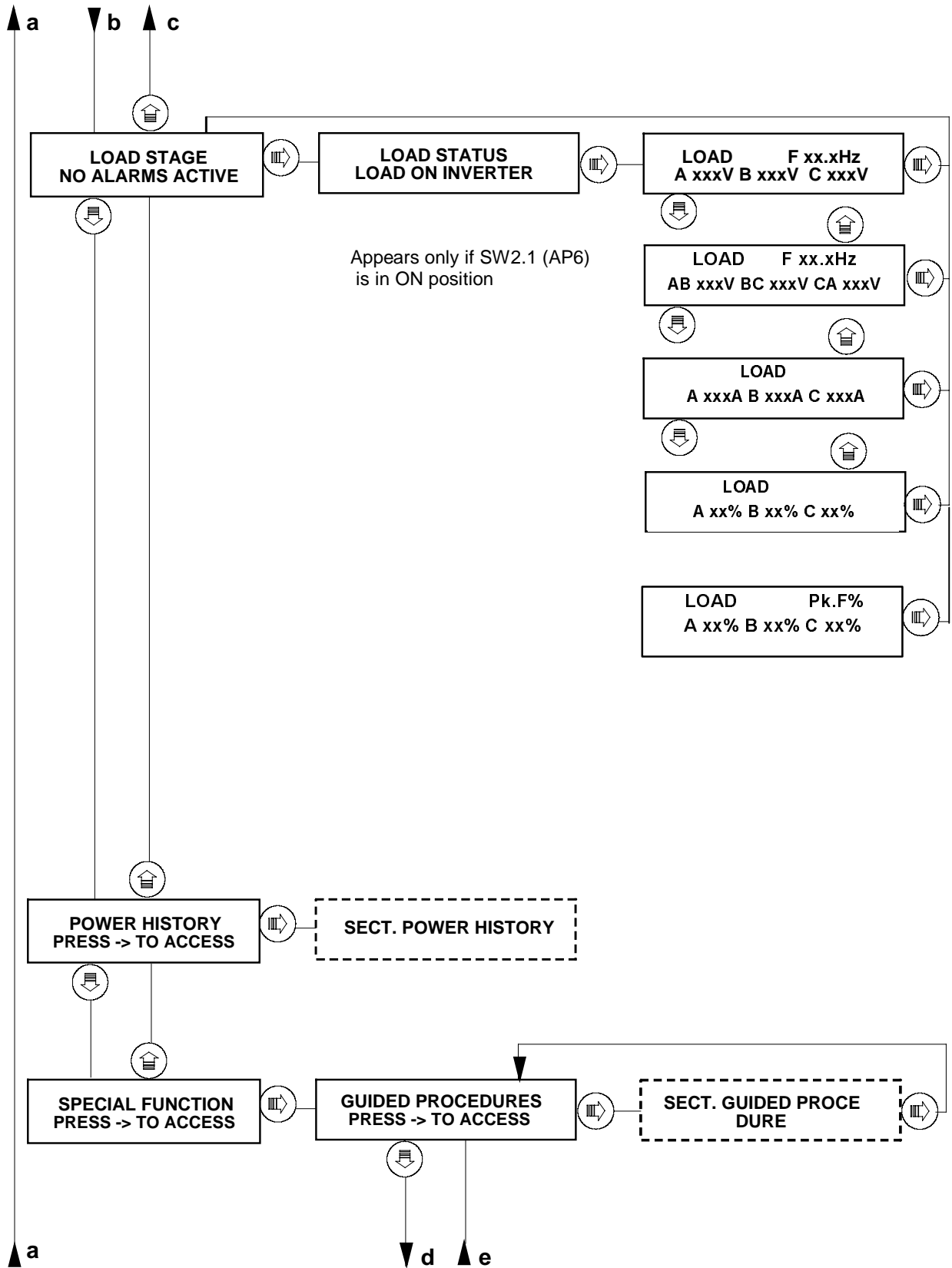

STAGE PAGE

STATUS PAGE

MEASUREMENTS PAGE:

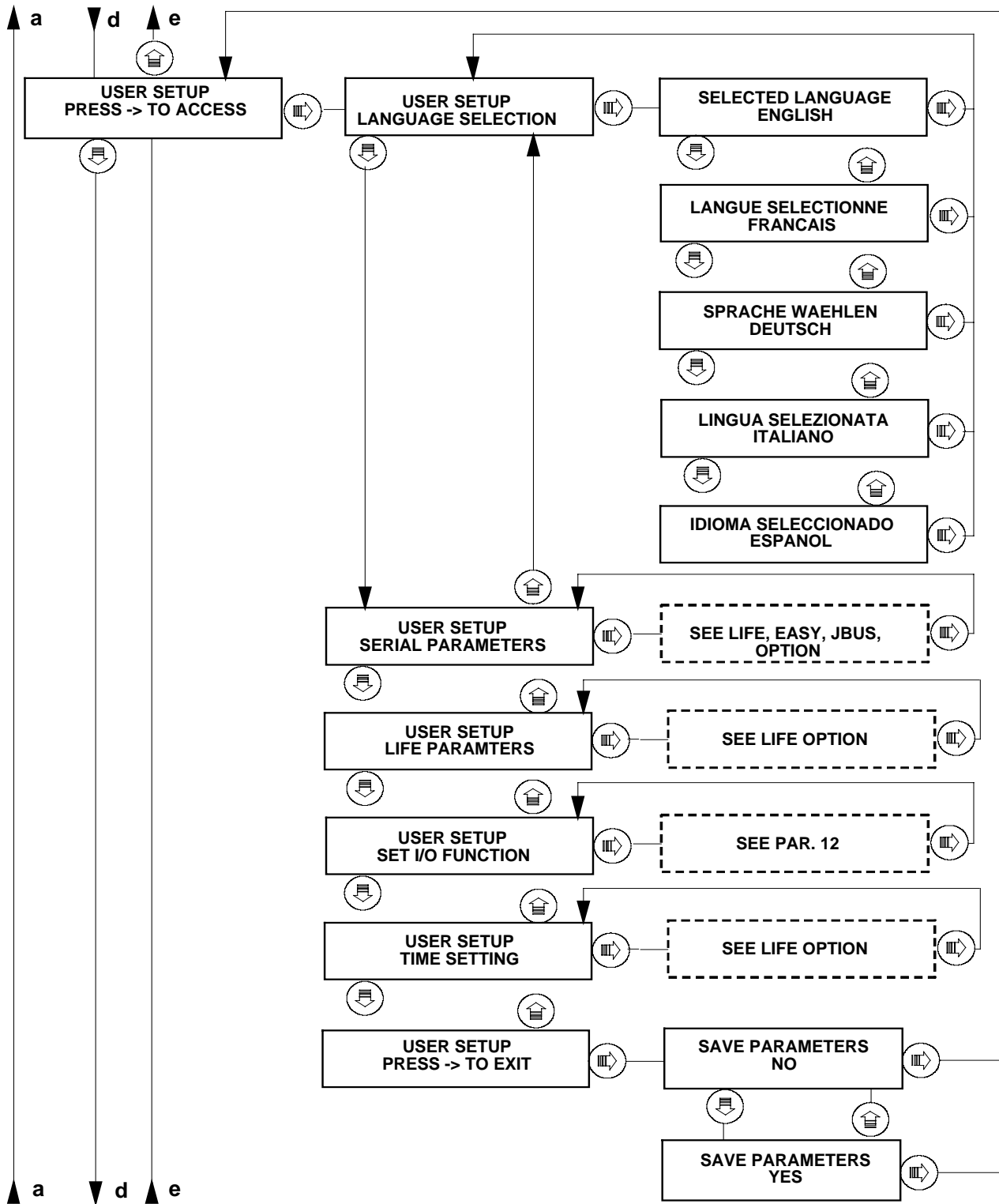

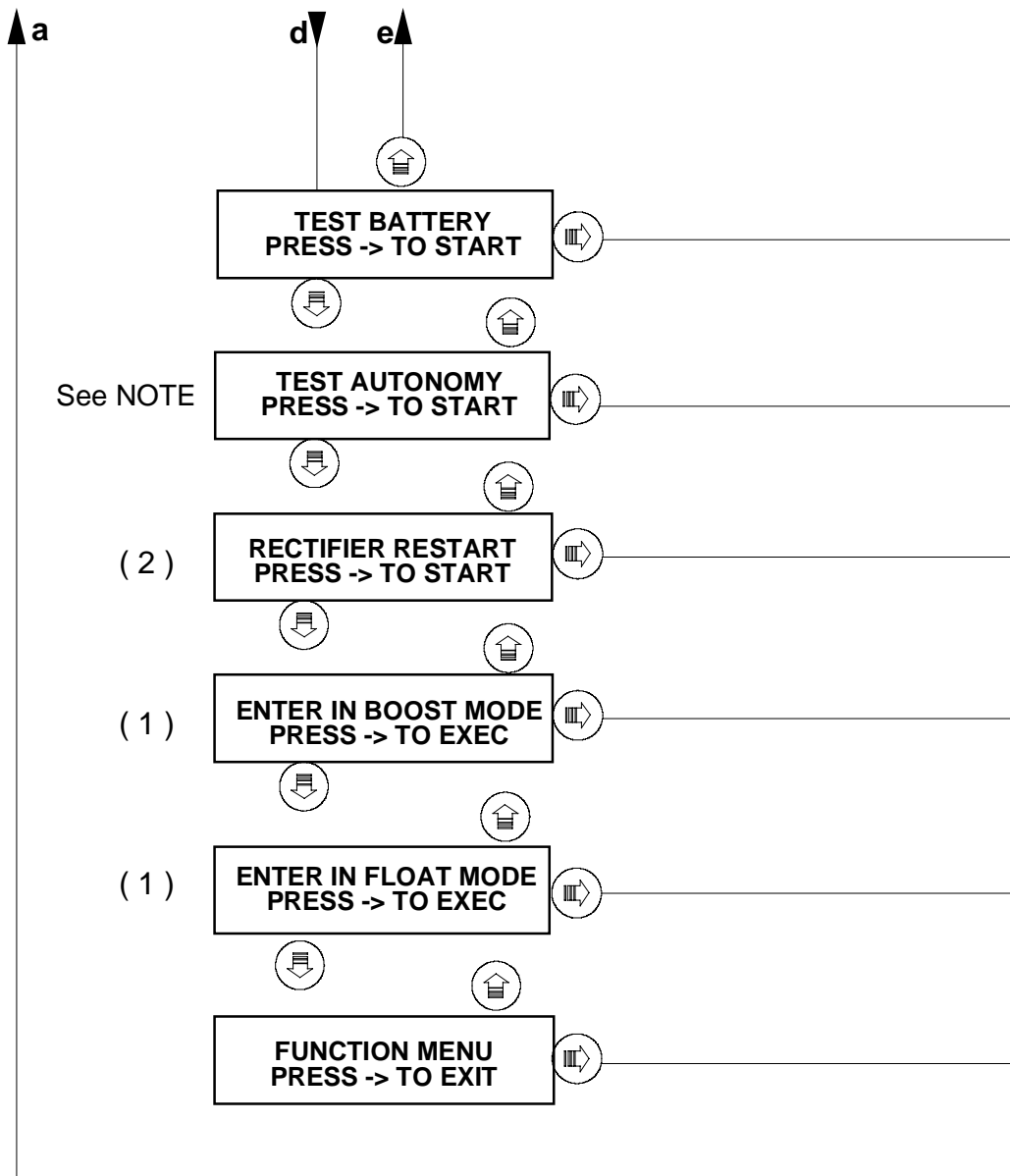

N.B.:

- (1) Messages active only with batteries accepting complete charge.
- (2) Messages active only when rectifier blocked.

NOTE: see AUTONOMY TEST

Description of alarm conditions

On the "ALARMS" (third) page it is possible to see one or more alarms. Each message is associated with one of the following conditions:

WARNING

Transitory conditions which can either return to normal condition or result in a permanent fault are identified under this heading. No intervention on the part of the operator is required.

FAULT

Fault conditions are identified under this heading. The attention of a qualified technician is required. Separate alarms which do not come under any of the above headings do not require intervention.

7.2 Description of system stages (status, alarms, measures)

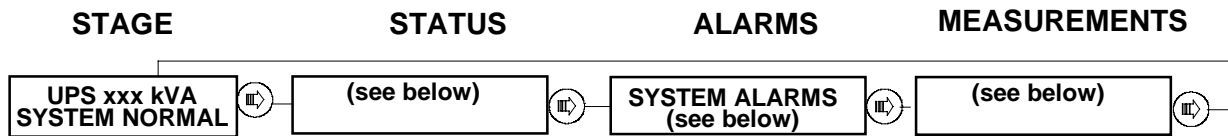

In the “SYSTEM” (first) page, the following conditions may appear in place of the SYSTEM NORMAL message:

- SYSTEM IN ALARM
- NO START ENABLED
- E.P.O. ACTIVE
- SETUP REQUEST
- SELF-TEST
- DO NOT INSERT BAT.

On the “STATUS” (second) page, machine status and other information will be displayed:

- Rev. y.yy zz / zz / zz Revision of machine software
10H00XXX

The “ALARMS” (third) page shows the active alarms.

Each message is associated with one of the following conditions:

MESSAGE	Condition
IIC BUS ERROR	FAULT
PCB SUPPLY FAULT	FAULT
OFF LINE (**)	WARNING
MICRO BOARD NOT CAL.	FAULT
MICRO B.REV.WARN.	FAULT
MICRO B.REV. FATAL	FAULT
E2PR-1 NOT CALIB.	FAULT
E2PR-1 REV.WARN.	FAULT
E2PR-1 REV FATAL	FAULT
E2PR-2 NOT CALIB.	FAULT
E2PR-2 REV.WARN.	FAULT
E2PR-2 REV.FATAL	FAULT
MEMORY NOT INITIAL.	FAULT
CMOS RETENTION LOST	FAULT
TK RETENTION LOST	FAULT

MESSAGE	Condition
INLET AIR TEMP. OUT RANGE/FAULT	FAULT
INLET AIR TEMP. OUT OF RANGE	FAULT
OUTLET AIR TEMP. OUT RANGE/FAULT	FAULT
OUTLET AIR TEMP. OUT OF RANGE	FAULT
REMOTE CMD INHIBITED (#)	WARNING
EPROM WRITE FAULT	FAULT
BACKUP BATT. FAULT	FAULT
INSUFF. VENTILATION (#)	FAULT

N.B.:

Messages marked by () apply only to Parallel UPS.**

(#) Alarm present only if the corresponding input/output function is ENABLED.

The "MEASUREMENTS" (fourth) page displays the following messages:

INLET AIR
Temp : xx °C/°F

Temperature of input air flow.

OUTLET AIR
Temp : xx °C/°F

Temperature of output air flow.

INLET AIR # 2
Temp : xx °C/°F

Temperature of air input flow in 2nd cubicle.

OUTLET AIR # 2
Temp : xx °C/°F

Temperature of air output flow in 2nd cubicle.

TIME ON INVERTER
xxd : xxh : xxm : xxs

Displays total time the load has been supplied by the INVERTER since machine was last switched off.

TIME ON BYPASS
xxd : xxh : xxm : xxs

Displays total time the load has been supplied by the BYPASS since machine was last switched off.

UTLY. FAILURES YY
Xxd : xxh : xxm : xxs

Displays number of Utility failures and total duration of same since machine was last switched off.

TOTAL UTLY. FAIL. YY
Xxd : xxh : xxm : xxs

Displays number of Utility failures and total duration of same since machine installation.

OFF LINE YY ()**
xxd : xxh : xxm : xxs

Displays number of off lines and duration since machine was last switched off.

TOTAL OFF LINE YY ()**
xxd : xxh : xxm : xxs

Displays number of off-lines and total duration since machine installation.

N.B.:

Messages marked by () only apply to Parallel UPS.**

7.3 RECTIFIER stage description

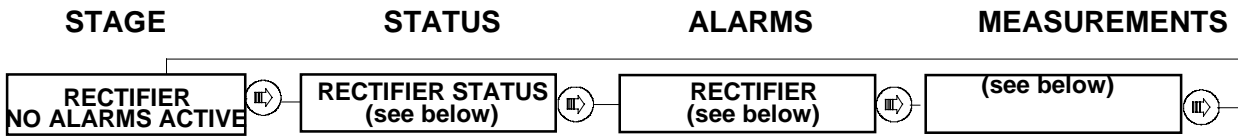

In the “RECTIFIER STAGE” (first) page one of the following conditions may appear in place of the NO ALARMS ACTIVE message:

- ALARMS ACTIVE
- NO START ENABLED
- E.P.O. ACTIVE.

The “RECTIFIER STATUS” (second) page gives information on rectifier status:

- RECTIFIER RUNNING
- RECTIFIER INHIBITED
- RECTIFIER BLOCKED
- TESTING BATTERY
- FLOAT CHARGE
- BOOST CHARGE

The “ALARMS” (third) page shows the activated alarms.

Each message is associated with one of the following conditions:

MESSAGE	Condition
HARMONIC FILTER OPEN	FAULT
UTILITY SUPPLY FAIL	WARNING
PHASE SEQUENCE ERROR	FAULT
DC VOLTAGE HIGH	FAULT
TESTING AUTONOMY	WARNING
INPUT SWITCH OPEN	WARNING
DC FEEDBACK FAULT	FAULT
DC SW CONTROL FAULT	WARNING
DC HW CONTROL FAULT	FAULT
BATT. CHARGE INHIBIT	WARNING
DC VOLTAGE LOW	WARNING
INSULATION FAILURE (#)	FAULT
UTLY. TRANSF. PROTECT (#)	FAULT

(#) Alarm present only if the corresponding input/output function is ENABLED.

The “MEASURES” (fourth) page gives the following measurements:

RECTIFIER Vdc xxxV Idc xxxA

Displays output voltage and current supplied by the RECTIFIER.

7.4 BATTERY stage description

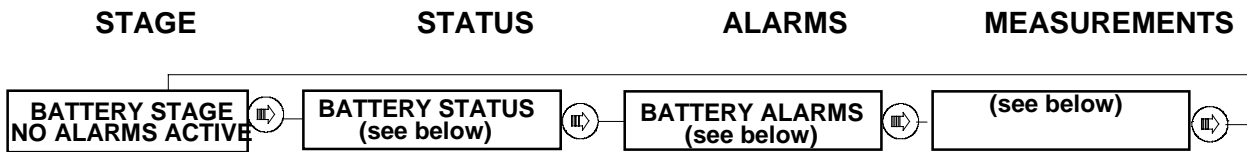

In the “BATTERY STAGE” (first) page one of the following conditions may appear in place of the NO ALARMS ACTIVE message:

- ALARMS ACTIVE
- NO START ENABLED
- E.P.O. ACTIVE

The “BATTERY STATUS” (second) page gives information on battery status:

- BATT. DISCONNECTED
- BATT. CONNECTED

The “ALARMS” (third) page displays the active alarms.

Each message is associated with one of the following conditions:

MESSAGE	Condition
BATT BREAKER OPEN	WARNING
BATTERY DISCHARGING	WARNING
SHUTDOWN IMMINENT	WARNING
BATTERY FAULT	FAULT
TEMP. OUT OF RANGE	FAULT
TEMPERATURE ALARM	WARNING
TEMP.OUT RANGE/FAULT	FAULT
DC VOLTAGE LOW	WARNING
INSULATION FAILURE (#)	FAULT
BATTERY FUSE BLOWN (#)	FAULT

(#) Alarm present only if the corresponding input/output function is ENABLED.

The “MEASUREMENTS” (fourth) page gives the following measurements:

BATTERY
Vdc xxxV Ib xxxA

Displays the battery voltage and CHARGE/DISCHARGE current.

BATTERY
Temp. : xx °C/°F

Displays temperature of the battery area.

When the battery is DISCHARGING, the LCD displays residual autonomy and discharge time information.

If no information on autonomy is available, the following message will be displayed:

BATTERY DISCHARGING
AUT calc xxmin DIS xxmin

When autonomy information is available, the following message will be displayed:

BATTERY DISCHARGING
AUT yymin DIS xxmin

where xx represents discharge time and yy battery residual autonomy.

7.5 INVERTER stage description

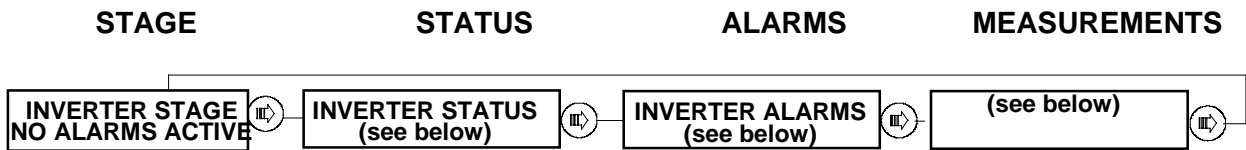

In the “INVERTER STAGE” (first) page one of the following conditions may appear in place of the NO ALARMS ACTIVE message :

- ALARMS ACTIVE
- E.P.O. ACTIVE
- NO START ENABLED

The “INVERTER STATUS” (second) page gives information on inverter status:

- INVERTER RUNNING
- INVERTER INHIBITED
- INVERTER NOT RUNNING
- INVERTER BLOCKED

The “ALARMS” (third) page shows the activated alarms.

Each message is associated with one of the following conditions:

MESSAGE	Condition
OUT OF SYNC	WARNING
DESATURATION	FAULT
OVER TEMPERATURE	FAULT
MAINT. SWITCH CLOSED	FAULT
SHUTDOWN IMMINENT	WARNING
DC VOLTAGE HIGH	FAULT
DC VOLTAGE LOW	WARNING
INVERTER VOLTS HIGH	FAULT
INVERTER VOLTS LOW	FAULT
OVERLOAD	WARNING
STOP DUE TO OVERLOAD	FAULT
CURRENT LIMIT	WARNING
INV. FREQ. OUT RANG. 8%	FAULT
INV. FREQ. OUT RANG. 1%	FAULT
INV. FEEDBACK FAULT	FAULT
VERIFYING INV. FREQ.	WARNING
REMOTE INV. STOPPED (#)	WARNING
VERIFYING BATT.CONT.	WARNING
INV.ST. SWITCH FAULT	FAULT
REF. FREQUENCY ERROR (**)	FAULT

MESSAGE	Condition
OUT OF SYNC OR DISC. (**)	FAULT
UPS SELF DISCONNECT. (**)	FAULT
WAIT Vdc IN RANGE	WARNING
BACKFEED CONTACT CLOSED	FAULT

*N.B.: Messages marked with (**) are for UPS Parallel configuration only.*

(#) Alarm present only if the corresponding input/output function is ENABLED.

When an OVERLOAD alarm is present, the units calculate the time remaining before INVERTER shutdown.

The following message will appear:

<p>OVERLOADxxx INV STOP xxm : yys</p>
--

If the INVERTER is DISABLED due to overload, the time remaining before INVERTER reactivation will be displayed in the following message:

<p>STOP DUE TO OVERLOAD RESTART IN xxm : yys</p>

The “MEASUREMENTS” (fourth) page gives the following measures:

<p>INVERTER F xx.xHz A xxxV B xxxV C xxxV</p>
--

Displays INVERTER voltage and frequency

<p>INVERTER F xx.xHz AB xxxV BC xxxV CA xxxV</p>

Displays INVERTER phase to phase voltage and frequency

<p>INVERTER A xxxA B xxxA C xxxA</p>

Displays INVERTER current

<p>OVERLOAD THRESHOLD xxx % (@ yyy 5C)</p>

Displays overload threshold temperature.

7.6 BYPASS stage description

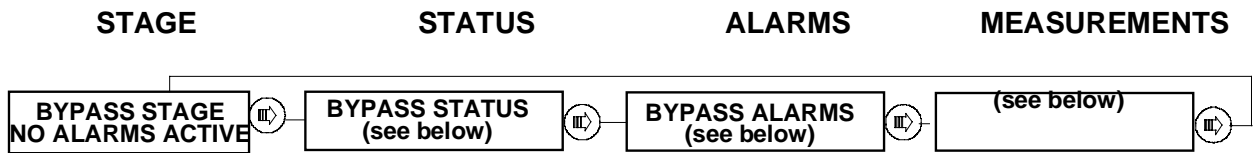

In the “BYPASS STAGE” (first) page one of the following conditions may appear in place of the NO ALARMS ACTIVE message:

- ALARMS ACTIVE
- NO START ENABLED
- E.P.O. ACTIVE.

The “STATUS” (second) page gives information on Bypass status:

- BYPASS VALID
- BYPASS NOT VALID
- BYPASS INHIBITED

The “ALARMS” (third) page displays the activated alarms.

Each message is associated with one of the following conditions:

MESSAGE	Condition
BYPASS VOLTS HIGH	WARNING
BYPASS VOLTS LOW	WARNING
BYPASS SWITCH OPEN	FAULT
PHASE SEQUENCE ERROR	FAULT
BYPASS FREQ FAULT	WARNING
OVERLOAD	WARNING
PAR.BACKFEED VOLTAGE (**)	WARNING
BYPASS SUPPLY FAULT	WARNING
BACKFEED PROT ACTIVE	FAULT
BYP. TRANSF. PROTECT (#)	FAULT
BACKFEED ON PHASE A	FAULT
BACKFEED ON PHASE B	FAULT
BACKFEED ON PHASE C	FAULT

The “MEASUREMENTS” (fourth) page gives the following measures:

```
BYPASS  F xx.xHz
A xxxV B xxxV C xxxV
```

Displays the frequency and voltage of the BYPASS line.

```
BYPASS  F xx.xHz
AB xxxV BC xxxV CA xxxV
```

Displays frequency and phase-phase voltage of the BYPASS line

*N.B.: Messages marked with (**) are for DISTRIBUTED parallel configurations only.*

(#) Alarm present only if the corresponding input/output function is ENABLED.

7.7 LOAD stage description

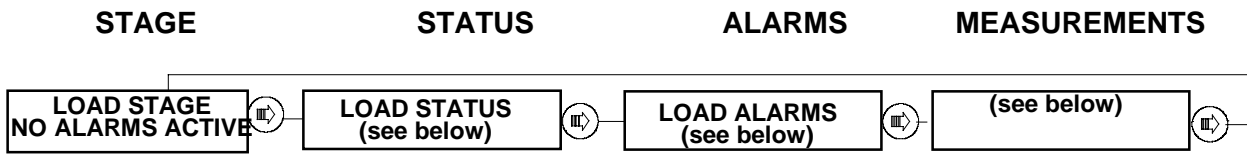

The “LOAD STAGE” (first) page one of the following conditions may appear in place of the NO ALARMS ACTIVE message:

- ALARMS ACTIVE
- NO START ENABLED
- E.P.O. ACTIVE.

The “STATUS” (second) page gives information load status:

- LOAD NOT SUPPLIED
- LOAD ON INVERTER
- LOAD ON BYPASS
- LOAD ON MAINT.

The “ALARMS” (third) page shows activated alarms.

Each message is associated with one of the following messages:

MESSAGE	CONDITION
MAINT. SWITCH CLOSED	FAULT
ST.SW.BLOCKED ON INV	FAULT
ST.SW.BLOCKED ON BYP	FAULT
OUTPUT SWITCH OPEN	FAULT
INV.ST. SWITCH FAULT	FAULT
OVERLOAD	WARNING
INSULATION FAILURE (#)	FAULT
SYS.MAINT. SW CLOSED (**)(#)	FAULT
SYSTEM OUTPUT SW OPEN (**)(#)	FAULT

N.B.:

*Messages marked with (**) are for UPS Parallel configuration only.*

(#) Alarm present only if the corresponding input/output function is ENABLED.

The "MEASUREMENTS" (fourth) page gives the following measurements:

LOAD F xx.xHz A xxxV B xxxV C xxxV
--

Displays the frequency and voltage supplied to the LOAD.

LOAD F xx.xHz AB xxxV BC xxxV CA xxxV

Displays frequency and phase-phase voltage supplied to LOAD.

LOAD A xxxA B xxxA C xxxA
--

Displays the current supplied to the LOAD.

LOAD A xx % B xx % C xx %
--

Displays the LOAD percentage.

LOAD Pk.F A xx % B xx % C xx %
--

Displays the Peak Factor of the LOAD current.

8. POWER HISTORY

STAGE POWER HISTORY ON THE UPS UNIT

The Power History function, (red led flashing), is only available in the following conditions:

- 1) Any condition that leads to inverter blockage.
- 2) The following 3 inverter disable conditions:
 - DC VOLTAGE HIGH
 - DC SW CONTROL FAULT
 - MAINT. & OUTPUT CLOSURE
- 3) UPS off line (parallel only).

Press the start inverter pushbutton to erase the setting.

Figure X illustrates how to access Power History.

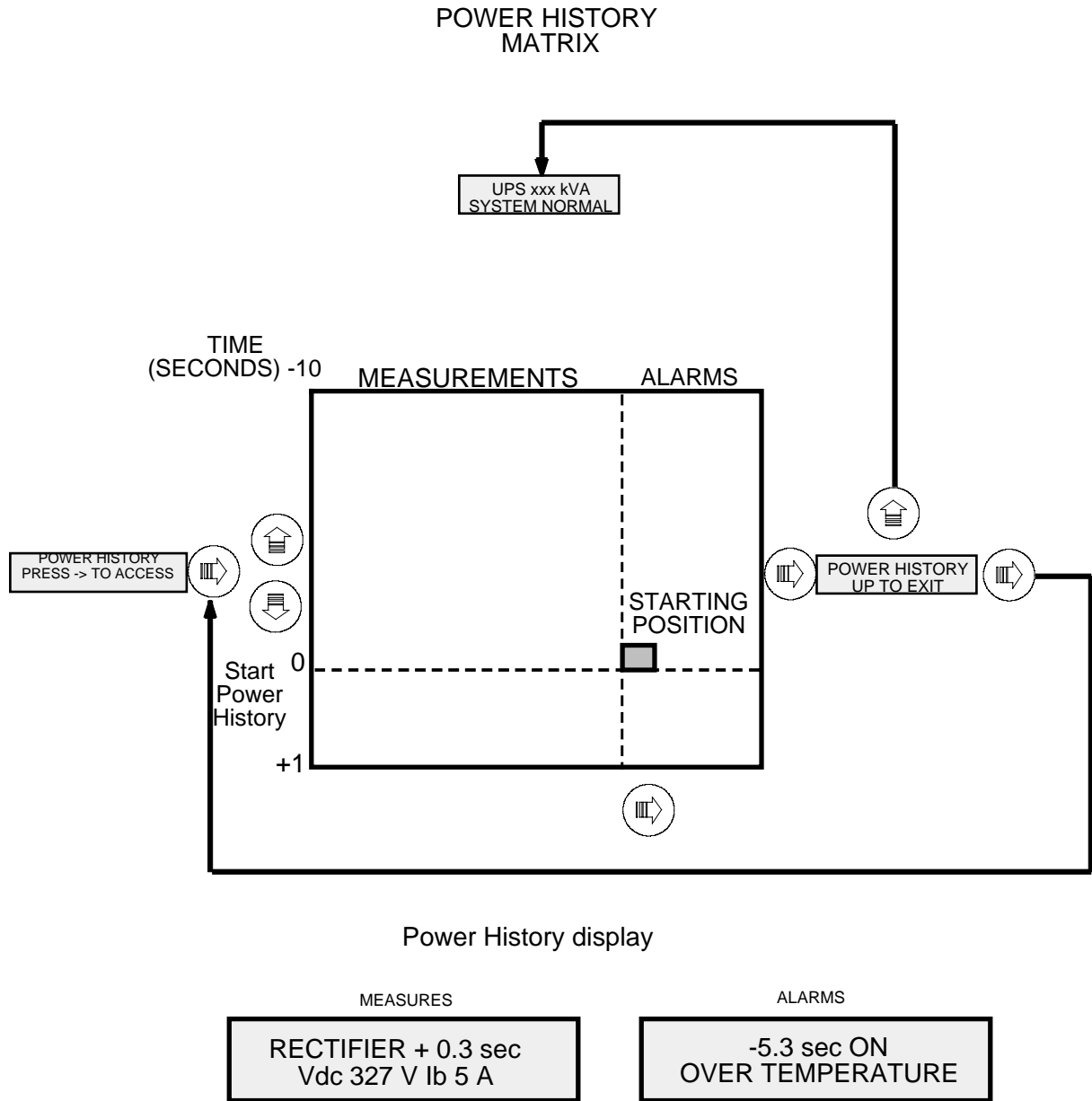



Figure X

9. GUIDED PROCEDURE

9.1 EDP90 Single unit

From the "GUIDED PROCEDURE" page, press  to access the 4 procedures below:

- MAINT. BYPASS
- RETURN FROM MAINT. (*)
- START UP (*)
- SHUTDOWN

(*) = Control logic is not supplied when the UPS is stopped or in MAINT. BYPASS To follow guided procedure, either the UTILITY input switch or the BYPASS input switch must be closed.

If requested procedure is incompatible with the machine status, the procedure will not be accessed and the following message will appear:

"PROCEDURE NOT OK".

The microprocessor makes sure that each procedure is performed correctly, giving step-by-step instructions to the operator for the manual operations required.

When an operation has been executed or a required condition has been verified, the message relating to the next step is displayed until the procedure has been completed.

If a required operation is not executed or a condition is not verified, a message will be displayed showing the status that temporarily or permanently prevents the procedure from being completed.

If the procedure has been successfully completed, the message

"PROCEDURE COMPLETE".

will be displayed.

Press  to exit the procedure at any time.

The maximum number of messages that can be displayed is listed on the following pages.

Each message may contain an operation request or an indication. Each message is flanked by the type of message (operation or indication) and the description.

N.B.
If the current procedure cannot be completed due to permanent alarms or blocking conditions, the operator (depending on level of personal training) must:

- call Back-up assistance;

or

- follow the instructions given in the "Troubleshooting" chapter of the Technical Manual.

Symbols



MAINT. BYPASS PRESS ---> TO ACCESS

 = example of display message.



 = example of control panel pushbutton.

Procedure selection

The following messages relate to the 4 procedures available for selection. The pushbuttons to access and scroll each procedure are also illustrated.

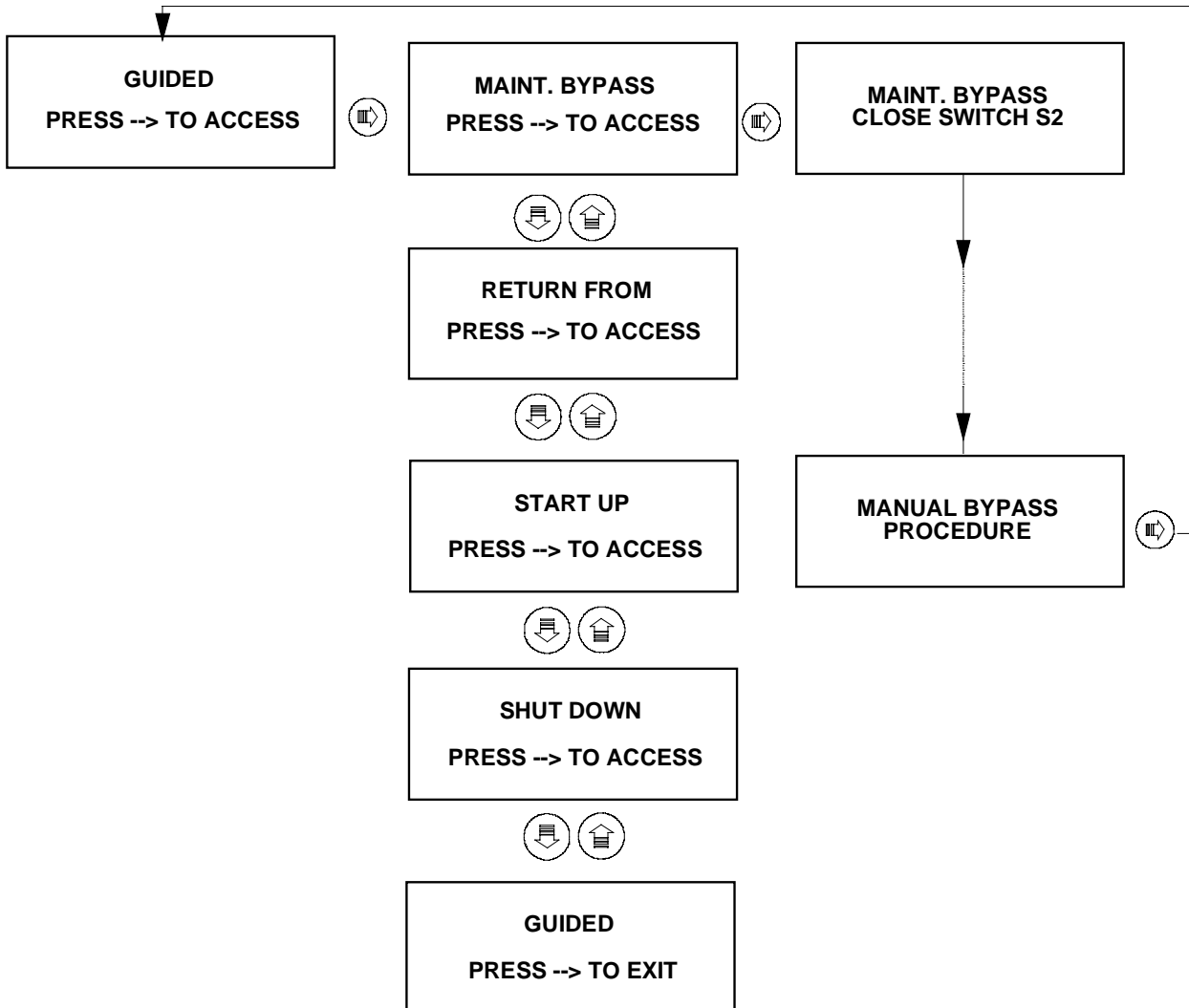

Press  to access a procedure; if the machine status permits the operation, the first message will be displayed. Once the procedure has been completed, press  to return to the "GUIDED PROCEDURE" page. The diagram below represents the "MAINT. BYPASS." procedure.



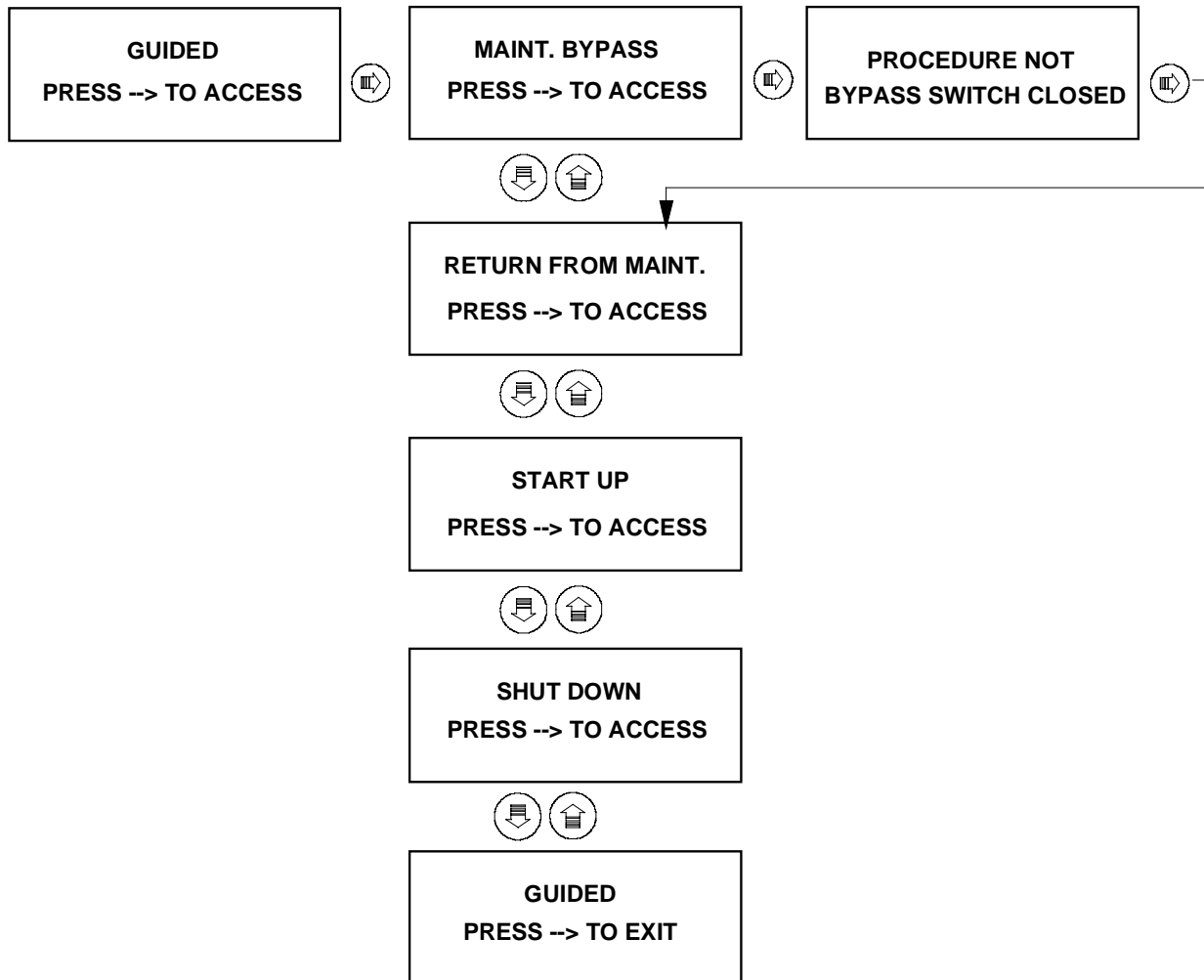

Press  to access a procedure; if the machine status does not permit the operation, the message "PROCEDURE NOT OK" will appear with the machine status message. Press  once again to move on to the next procedure. The diagram below illustrates a MAINT. BYPASS request when the UPS is already in the MAINT. condition.



Single UPS MAINT. BYPASS procedure



MAINT. BYPASS E.P.O. ACTIVE	Indication	Procedure not possible while E.P.O. is active.
MAINT. BYPASS CLOSE SWITCH S2	Request for intervention	Close BYPASS S2 switch
MAINT. BYPASS WAIT BYPASS OK	Indication	System is awaiting OK from BYPASS.
MAINT. BYPASS WAIT INV.PHASE LOCK	Indication	System is awaiting sync between inverter and BYPASS.
MAINT. BYPASS ST.SW.BLOCKED ON INV	Indication	Static switch on inverter is blocked. WARNING: load supply will be terminated if procedure is continued.
MAINT. BYPASS STOP INVERTER	Request for intervention	Stop inverter. Press for at least 2 seconds pushbutton 
MAINT. BYPASS WAIT LOAD ON BYPASS	Indication	The system is waiting for load on BYPASS.
MAINT. BYPASS CLOSE SWITCH S3	Request for intervention	Close MAINT. switch S3.
MAINT. BYPASS OPEN SWITCH S4	Request for intervention	Open output switch S4.
MAINT. BYPASS OPEN SWITCH S2	Request for intervention	Open BYPASS switch S2.
MAINT. BYPASS OPEN SWITCH S1	Request for intervention	Open input switch S1.
MAINT. BYPASS PROCEDURE COMPLETE	Request for intervention	Press  to exit.

Single UPS RETURN FROM MAINT. procedure



RETURN FROM MAINT. E.P.O. ACTIVE	Indication	Procedure not possible while E.P.O. is active.
RETURN FROM MAINT. CLOSE SWITCH S2	Request for intervention	Close BYPASS switch S2
RETURN FROM MAINT. WAIT BYPASS OK	Indication	System is awaiting BYPASS OK.
RETURN FROM MAINT. STOP INVERTER	Request for intervention	Stop inverter. Press for at least 2 seconds pushbutton 
RETURN FROM MAINT. CLOSE SWITCH S4	Request for intervention	Close output switch S4 .
RETURN FROM MAINT. ST.SW.BLOCKED ON INV	Indication	Static switch on inverter is blocked. WARNING: load supply will be terminated if procedure is continued.
RETURN FROM MAINT. OPEN SWITCH S3	Request for intervention	Open MAINT. switch S3 .
RETURN FROM MAINT. CLOSE SWITCH S1	Request for intervention	Close input switch S1 .
RETURN FROM MAINT. WAIT Vdc IN RANGE	Indication	The system waits for the rectifier dc output voltage to reach 2 V/cell.
RETURN FROM MAINT. START INVERTER	Request for intervention	Switch on inverter. Press pushbutton 
RETURN FROM MAINT. WAIT INVERTER START	Indication	System is awaiting inverter drive. Inverter will not start in the following conditions: -- inverter frequency does not reach nominal value (i.e. 1% of tolerance) during BYPASS failure; -- battery contactor is not closed.
RETURN FROM MAINT. INVERTER INHIBITED	Indication	Inverter is disabled.

RETURN FROM MAINT. INVERTER BLOCKED	Indication	Inverter is blocked.
RETURN FROM MAINT. ST.SW.BLOCKED ON INV	Indication	Static switch is blocked on inverter.
RETURN FROM MAINT. ST.SW.BLOCKED ON BYP	Indication	Static switch is blocked on BYPASS supply (load is not on inverter).
RETURN FROM MAINT. WAIT LOAD ON INV.	Indication	System is awaiting load on inverter.
RETURN FROM MAINT. PROCEDURE COMPLETE	Request for intervention	Press  to exit.

Single UPS START UP procedure

START UP E.P.O. ACTIVE	Indication	Procedure not possible while E.P.O. is active.
START UP CLOSE SWITCH S1	Request for intervention	Close input switch S1 .
START UP WAIT Vdc IN RANGE	Indication	The system waits for the rectifier dc output voltage to reach 2 V/cell.
START UP CLOSE SWITCH S2	Request for intervention	Close BYPASS switch S2 .
START UP WAIT BYPASS OK	Indication	System awaiting BYPASS OK.
START UP CLOSE SWITCH S4	Request for intervention	Close output switch S4 .
START UP START INVERTER	Request for intervention	Switch on inverter. Press pushbutton 
START UP WAIT INVERTER START	Indication	System is awaiting inverter drive. Inverter will not start in the following conditions: -- inverter frequency does not reach nominal value (i.e. 1% of tolerance) during BYPASS failure; -- battery contactor is not closed.
START UP INVERTER INHIBITED	Indication	Inverter is disabled.
START UP INVERTER BLOCKED	Indication	Inverter is blocked.
START UP ST.SW.BLOCKED ON INV	Indication	Static switch is blocked on inverter.
START UP ST.SW.BLOCKED ON BYP	Indication	Static switch is blocked on BYPASS (load is not on inverter).
START UP WAIT LOAD ON INV.	Indication	System is waiting for load on inverter.
START UP PROCEDURE COMPLETE	Request for intervention	Press  to exit.

Single UPS SHUT DOWN procedure

SHUT DOWN E.P.O. ACTIVE	Indication	Procedure not possible while E.P.O. is active.
SHUT DOWN OPEN SWITCH S3	Request for intervention	Open MAINT. BYPASS switch S3 .
SHUT DOWN OPEN SWITCH S2	Request for intervention	Open BYPASS switch S2 .
SHUT DOWN STOP INVERTER	Request for intervention	Stop inverter. Press for at least 2 seconds pushbutton 
SHUT DOWN OPEN SWITCH S4	Request for intervention	Open output switch S4 .
SHUT DOWN OPEN SWITCH S1	Request for intervention	Open input switch S1 .
SHUT DOWN PROCEDURE COMPLETE	Request for intervention	Press  to exit.

9.2 EDP90 DISTRIBUTED parallel system

The guided procedure for distributed parallel systems differs from the SYSTEM and SINGLE UPS procedures.

From the "GUIDED PROCEDURE" page, press  to access the 6 procedures below:

SYSTEM procedure

- MAINT. BYPASS
- RETURN FROM MAINT. (*)
- SYSTEM START UP (*)
- SYSTEM SHUT DOWN

(*) = Control logic is not supplied when the UPS is switched off. To follow guided procedure, either the BYPASS INPUT switch or the UTILITY INPUT switch must be closed.



single UPS procedure.

- UPS START UP (*);
- UPS SHUT DOWN

SYSTEM PROCEDURES

SYSTEM procedures can be accessed from any UPS within the system.

Each operation requested by the current message must be performed on all UPS units; completion of all operation stages on the UPS displaying the SYSTEM procedure is recommended.

Each stage of the procedure (except the first) is requested by pressing pushbutton ; once the required operation and checks have been performed on all UPS, press  to display the next step. If the procedure has been successfully completed, the message

"PROCEDURE COMPLETE".

will be displayed.

Press  to exit the procedure at any time.

The maximum number of messages that can be displayed is listed on the following pages.

Each message may contain an operation request or an indication. Each message is flanked by the type of message (operation or indication) and the description.

N.B. If the current procedure cannot be completed due to permanent alarms or blocking conditions, the operator (depending on level of personal training) must:

- call Back-up assistance;

or

- follow the instructions given in the "Troubleshooting" chapter of the Technical Manual.

SINGLE UPS PROCEDURES

The microprocessor makes sure that each procedure is performed correctly, giving step-by-step instructions to the operator for the manual operations required.

When an operation has been executed or a required condition has been verified, the message relating to the next step is displayed until the procedure has been completed.

If a required operation is not executed or a condition is not verified, a message will be displayed showing the status that temporarily or permanently prevents the procedure from being completed.

If the procedure has been successfully completed, the message

"PROCEDURE COMPLETE".

will be displayed.



Press  to exit the procedure at any time.

The maximum number of messages that can be displayed in the two distributed parallel configurations (with or without SBS) is given on the following pages. Each message may contain an operation request or an indication. Each message is flanked by the type of message (operation or indication) and the description.

N.B.

If the current procedure cannot be completed due to permanent alarms or blocking conditions, the operator (depending on level of personal training) must:

- call Back-up assistance;

or

- follow the instructions given in the "Troubleshooting" chapter of the Technical Manual.

Symbols



= example of display message.





= example of control panel pushbutton.

Procedure selection



The following messages relate to the 6 procedures available for selection. The pushbuttons to access and scroll each procedure are also illustrated.

SYSTEM PROCEDURE

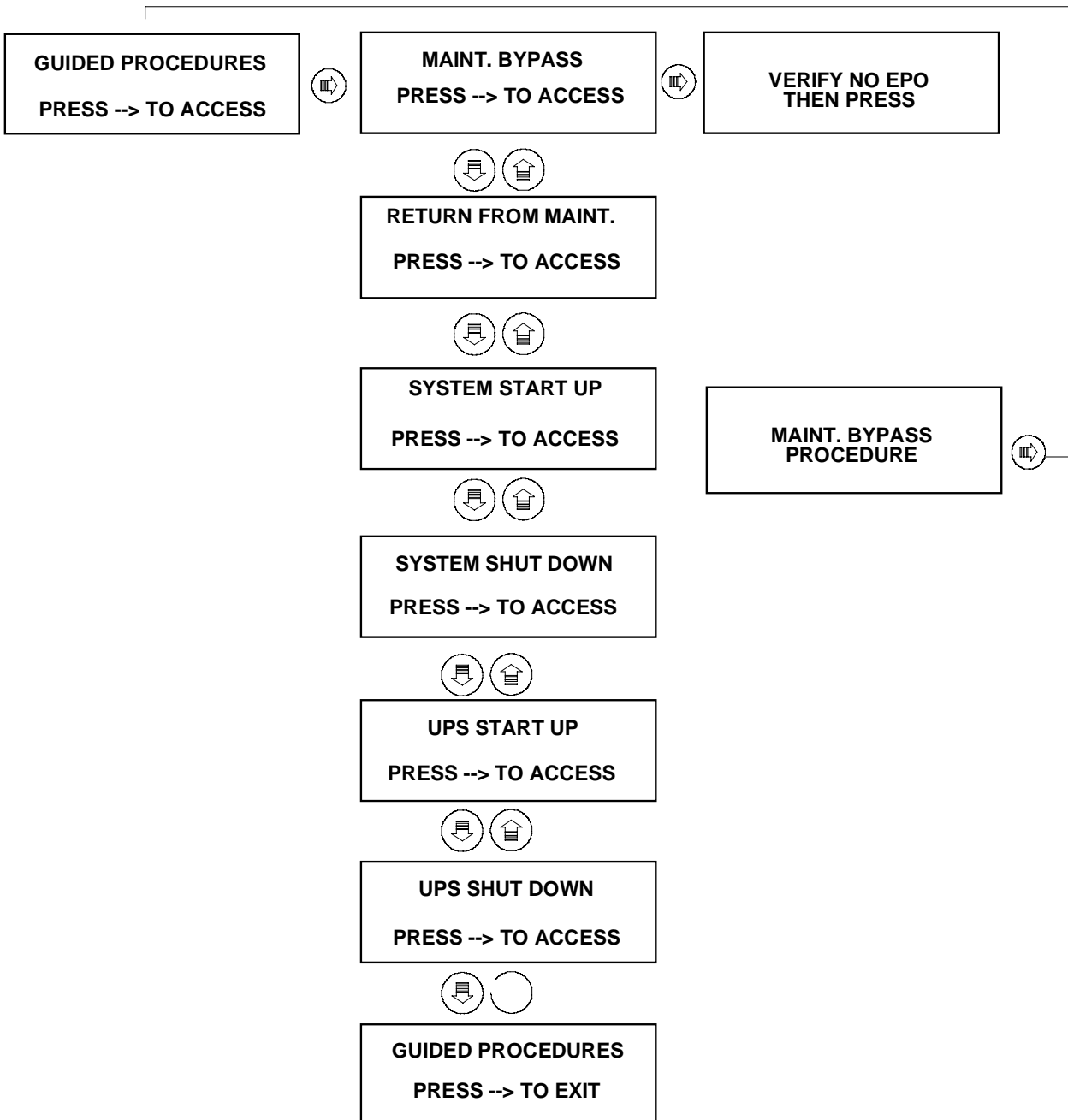
Press  to access a procedure; if the machine status permits the operation, the first message will be displayed. Once the procedure has been completed, press  to return to the "GUIDED PROCEDURE" page. The diagram below represents the "MAINT. BYPASS" procedure.



Single UPS procedure

Press  to access a procedure; if the machine status permits the operation, the first message will be displayed. Once the procedure has been completed, press  to return to the "GUIDED PROCEDURE" page. The diagram below represents the "UPS START UP" procedure.

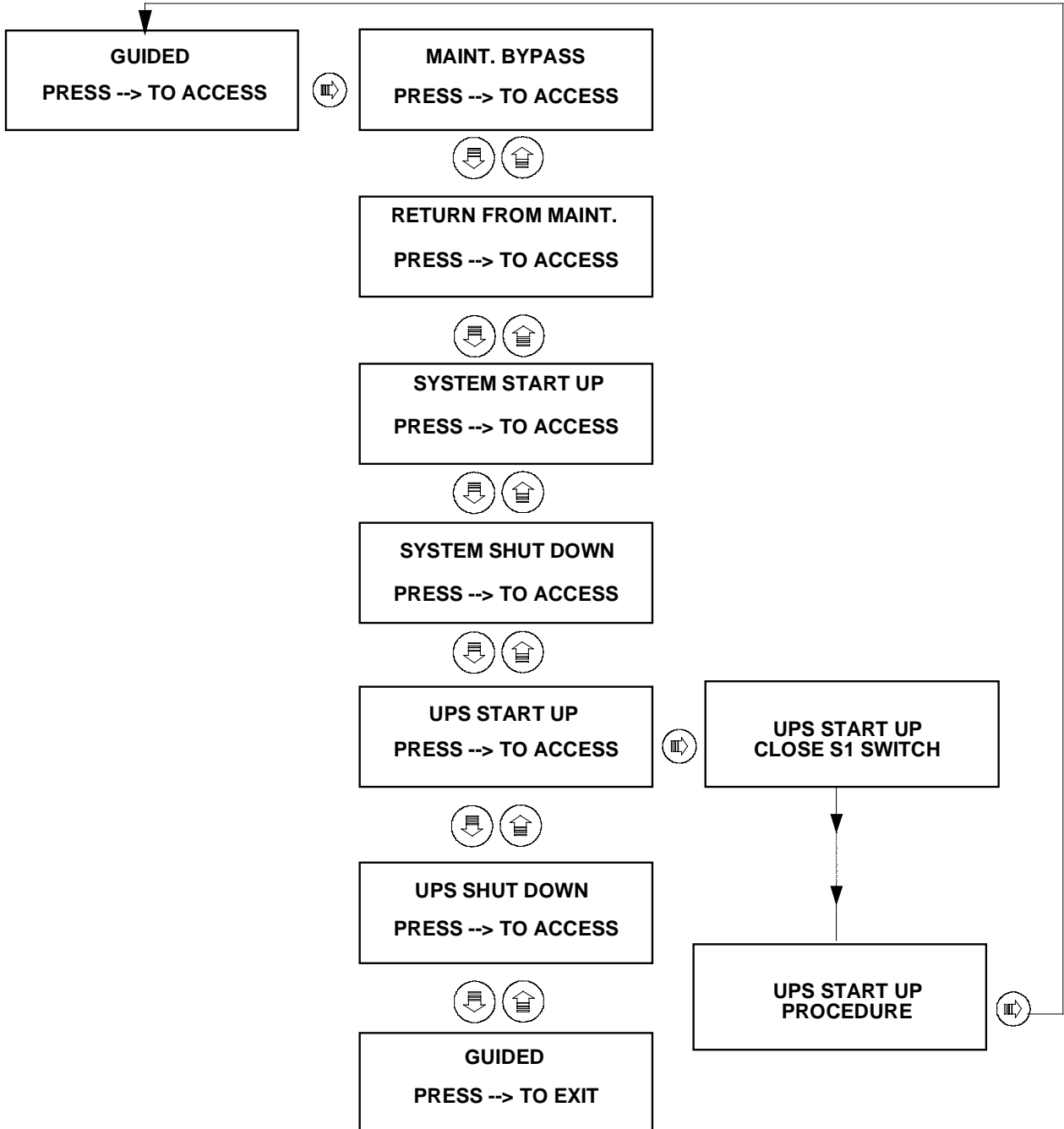

Press  to access a procedure; if the machine status does not permit the operation, the message





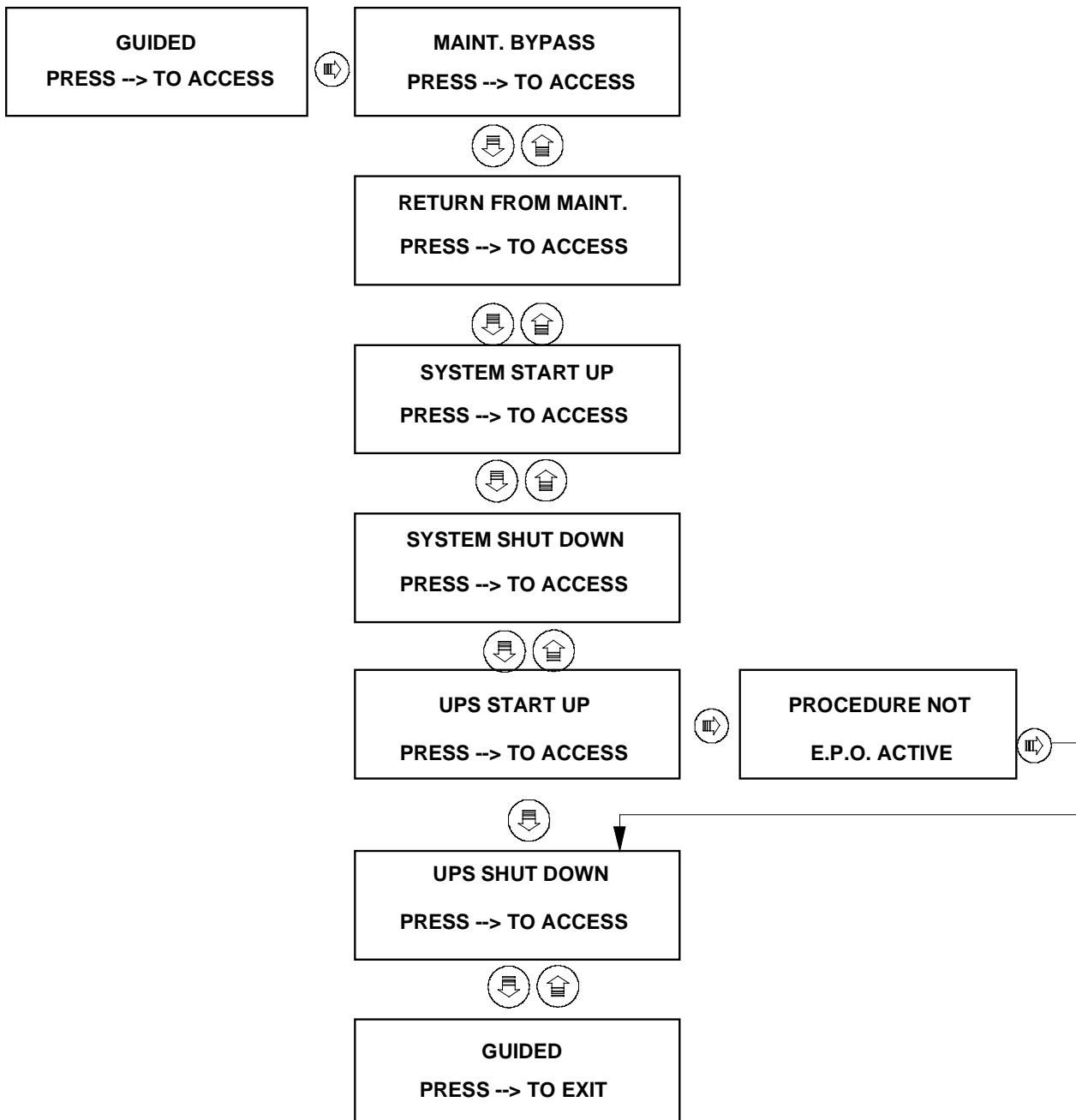









"PROCEDURE NOT OK" will appear with the machine status message. Press  once again to move on to the next procedure.

The diagram below illustrates a "UPS START UP" request when the UPS has detected an E.P.O. active condition (Emergency shutdown).

















DISTRIBUTED PARALLEL system with SBS

System MAINT. BYPASS procedure

VERIFY NO EPO ACTIVE THEN PRESS BUZZER	Request for verification	Verify that E.P.O. is not active. If active, procedure is incompatible and must be suspended. Press  to proceed to next stage.
CLOSE UPS S2 SWITCH THEN PRESS BUZZER	Request for intervention	Close Byp. switch S2 on UPS units. Press  to proceed to next stage.
WAIT BYPASS OK THEN PRESS BUZZER	Request for intervention	Wait for BYPASS OK. Press  to proceed to next stage.
CHECK BYPASS NUMBER THEN PRESS BUZZER	Request for intervention	Check that the number of BYPASS supplies is compatible with current load, bearing redundancy in mind. Press  to proceed to next stage. Wait for sync between BYPASS and UPS inverters.
WAIT INV.PHASE LOCK THEN PRESS BUZZER	Request for intervention	Press  to proceed to next stage.
ST.SW.BLK ON INV.? THEN PRESS BUZZER	Request for verification	Check that static switch is not blocked on inverter. Press  to proceed to next stage.
STOP UPS INVERTER THEN PRESS BUZZER	Request for intervention	Stop UPS inverters by pressing pushbutton  for at least 2 secs. Press  to proceed to next stage.
CLOSE SYS.S5 SWITCH THEN PRESS BUZZER	Request for intervention	Close system MAINT. switch S5 . Press  to proceed to next stage.
OPEN SYS.S6 SWITCH THEN PRESS BUZZER	Request for intervention	Open system output switch S6 . Press  to proceed to next stage.
OPEN UPS S4 SWITCH THEN PRESS BUZZER	Request for intervention	Open UPS output switch S4 . Press  to proceed to next stage.
OPEN UPS S2 SWITCH THEN PRESS BUZZER	Request for intervention	Open UPS BYPASS switch S2 . Press  to proceed to next stage.
CLOSE UPS QS1 SWITCH THEN PRESS BUZZER	Request for intervention	Open UPS input switch QS1 . Press  to proceed to next stage.
MAINT. BYPASS PROCEDURE COMPLETE	Request for intervention	Press  to exit.

System RETURN FROM MAINT. BYPASS procedure

<p>VERIFY NO EPO ACTIVE THEN PRESS BUZZER</p>	<p>Request for verification</p>	<p>Verify that E.P.O. is not active. If active, procedure is incompatible and must be suspended. Press  to proceed to next stage.</p>
<p>CLOSE UPS S2 SWITCH THEN PRESS BUZZER</p>	<p>Request for intervention</p>	<p>Close Bypass switch S2 on UPS units. Press  to proceed to next stage.</p>
<p>WAIT BYPASS OK THEN PRESS BUZZER</p>	<p>Request for intervention</p>	<p>Wait for acknowledgement of Bypass OK. Press  to proceed to next stage.</p>
<p>CHECK BYPASS NUMBER THEN PRESS BUZZER</p>	<p>Request for verification</p>	<p>Check that the number of Bypasss is compatible with current load, bearing redundancy in mind. Press  to proceed to next stage.</p>
<p>STOP UPS INVERTER THEN PRESS BUZZER</p>	<p>Request for intervention</p>	<p>Stop UPS inverters by pressing pushbutton  for at least 2 seconds. Press  to proceed to next stage.</p>
<p>CLOSE UPS S4 SWITCH THEN PRESS BUZZER</p>	<p>Request for intervention</p>	<p>Close UPS output switch S4. Press  to proceed to next stage.</p>
<p>CLOSE SYS.S6 SWITCH THEN PRESS BUZZER</p>	<p>Request for intervention</p>	<p>Close system output switch S6. Press  to proceed to next stage.</p>
<p>ST.SW.BLK ON INV.? THEN PRESS BUZZER</p>	<p>Indication</p>	<p>Check that static switch is not blocked on inverter. Press  to proceed to next stage.</p>
<p>OPEN SYS.S5 SWITCH THEN PRESS BUZZER</p>	<p>Request for intervention</p>	<p>Open system Maint. switch S5. Press  to proceed to next stage.</p>
<p>CLOSE UPS S1 SWITCH THEN PRESS BUZZER</p>	<p>Request for intervention</p>	<p>Close input switch S1 on UPS units. Press  to proceed to next stage.</p>
<p>START UPS INVERTER THEN PRESS BUZZER</p>	<p>Request for intervention</p>	<p>Start up inverter on UPS units by pressing pushbutton . Press  to proceed to next stage.</p>
<p>CHECK INV. NUMBER THEN PRESS BUZZER</p>	<p>Request for verification</p>	<p>Check that number of inverters is compatible with current load, bearing redundancy in mind. Press  to proceed to next stage.</p>

**ST.SW.BLK ON INV.?
THEN PRESS BUZZER**

Request for
verification

Check that the static switch on UPS
is not blocked on inverter.

Press  to proceed to next stage.

**ST.SW.BLK ON BYP.?
THEN PRESS BUZZER**

Request for
verification

Check that static switch is not
blocked on Bypass.

Press  to proceed to next stage.

**CHECK LOAD ON INV.
THEN PRESS BUZZER**

Request for
verification

Check that load is on inverter.















Press  to proceed to next stage.

**RETURN FROM MAINT.
BYPASS
PROCEDURE COMPLETE**









Request for
intervention

Press  to exit.



SYSTEM START UP procedure

VERIFY NO EPO ACTIVE THEN PRESS BUZZER	Request for verification	Ensure E.P.O. is not active. If active, procedure must be suspended. Press  to proceed to next stage.
CLOSE UPS S2 SWITCH THEN PRESS BUZZER	Request for intervention	Close Byp. sw. S2 on UPS units. Press  to proceed to next stage.
WAIT BYPASS OK THEN PRESS BUZZER	Request for intervention	Await acknowledgement of Byp. OK. Press  to proceed to next stage.
CHECK BYPASS NUMBER THEN PRESS BUZZER	Request for verification	Ensure the number of Bypass supplies is compatible with current load, bearing redundancy in mind. Press  to proceed to next stage.
CLOSE UPS S4 SWITCH THEN PRESS BUZZER	Request for intervention	Close UPS output switch S4 . Press  to proceed to next stage.
CLOSE SYS S6 SWITCH THEN PRESS BUZZER	Request for intervention	Close system output switch S6 . Press  to proceed to next stage.
CLOSE UPS S1 SWITCH THEN PRESS BUZZER	Request for intervention	Close input sw. S1 on UPS units. Press  to proceed to next stage.
START UPS INVERTER THEN PRESS BUZZER	Request for intervention	Start up inverter on UPS units by pressing pushbutton  . Press  to proceed to next stage.
CHECK INV. NUMBER THEN PRESS BUZZER	Request for verification	Check that the number of inverters is compatible with current load, bearing redundancy in mind. Press  to proceed to next stage.
ST.SW. BLK ON INV.? THEN PRESS BUZZER	Request for verification	Check that static switch on UPS is not blocked on inverter. Press  to proceed to next stage.
ST.SW. BLK ON BYP.? THEN PRESS BUZZER	Request for verification	Check that static switch on UPS is not blocked on Bypass. Press  to proceed to next stage.
CHECK LOAD ON INV. THEN PRESS BUZZER	Request for verification	Check that load is on inverter. Press  to proceed to next stage.
SYSTEM START UP PROCEDURE COMPLETE	Request for intervention	Press  to exit.



SYSTEM SHUT DOWN procedure

VERIFY NO EPO ACTIVE THEN PRESS BUZZER	Request for verification	Verify that E.P.O. is not active. If active, procedure is incompatible and must be suspended. Press  to proceed to next stage.
OPEN SYS.S5 SWITCH THEN PRESS BUZZER	Request for intervention	Open system Maint. Bypass switch S5 . Press  to proceed to next stage.
OPEN SYS.S6 SWITCH THEN PRESS BUZZER	Request for intervention	Open system output switch S6 . Press  to proceed to next stage.
OPEN UPS S2 SWITCH THEN PRESS BUZZER	Request for intervention	Open Bypass switch S2 on UPS units. Press  to proceed to next stage.
STOP UPS INVERTER THEN PRESS BUZZER	Request for intervention	Switch off UPS inverter by pressing pushbutton  for at least 2 seconds. Press  to proceed to next stage.
OPEN UPS S4 SWITCH THEN PRESS BUZZER	Request for intervention	Open UPS output switch S4 . Press  to proceed to next stage.
OPEN UPS S1 SWITCH THEN PRESS BUZZER	Request for intervention	Open input switch S1 on UPS units. Press  to proceed to next stage.
SYSTEM SHUT DOWN PROCEDURE COMPLETE	Request for intervention	Press  to exit.

Single UPS START UP procedure

UPS START UP E.P.O. ACTIVE	Indication	Procedure not possible while E.P.O. is active.
UPS START UP CLOSE SWITCH S1	Request for intervention	Close input switch S1 .
UPS START UP WAIT V _{dc} IN RANGE	Indication	The system waits for the rectifier dc output voltage to reach 2 V/cell.
UPS START UP CLOSE S2 SWITCH	Request for intervention	Close Bypass switch S2 .
UPS START UP WAIT BYPASS OK	Indication	System awaiting Bypass OK.
UPS START UP CLOSE SWITCH S4	Request for intervention	Close output switch S4 .
UPS START UP START INVERTER	Request for intervention	Press pushbutton  to start
UPS START UP WAIT INVERTER START	Indication	System is awaiting inverter drive. Inverter will not start in the following conditions: -- inverter frequency does not reach nominal value (i.e. 1% of tolerance) during Bypass failure; -- battery contactor is not closed.
UPS START UP INVERTER INHIBITED	Indication	Inverter is disabled.
UPS START UP INVERTER BLOCKED	Indication	Inverter is blocked.
UPS START UP ST.SW.BLOCKED ON INV	Indication	Static switch is blocked on inverter.
UPS START UP ST.SW.BLOCKED ON BYP	Indication	Static switch is blocked on Bypass (load is not on inverter).
UPS START UP WAIT LOAD ON INV.	Indication	System is waiting for load on inverter.
UPS START UP PROCEDURE COMPLETE	Request for intervention	Press  to exit.













Single UPS SHUT DOWN procedure

UPS SHUT DOWN E.P.O. ACTIVE	Indication	Procedure not possible while E.P.O. is active.
UPS SHUT DOWN OPEN S3 SWITCH	Request for intervention	Open Maint. Bypass switch S3 .
UPS SHUT DOWN OPEN S2 SWITCH	Request for intervention	Open Maint. Bypass switch S2 .
UPS SHUT DOWN STOP INVERTER	Request for intervention	Stop inverter pressing pushbutton  for at least 2 seconds
UPS SHUT DOWN OPEN S4 SWITCH	Request for intervention	Open output switch S4 .
UPS SHUT DOWN OPEN S1 SWITCH	Request for intervention	Open input switch S1 .
UPS SHUT DOWN PROCEDURE COMPLETE	Request for intervention	Press  to exit.

Distributed Parallel system

N.B. In this configuration, system MAINT. BYPASS is performed by the parallel arrangement of all the UPS MAINT. BYPASS switches; protections positioned upline of each UPS unit must therefore guarantee temporary load supply.

System MANUAL MAINT. BYPASS procedure

VERIFY NO EPO ACTIVE THEN PRESS BUZZER	Request for verification	Verify that E.P.O. is not active. If active, procedure is incompatible and must be suspended. Press  to proceed to next stage.
CLOSE UPS S2 SWITCH THEN PRESS BUZZER	Request for intervention	Close Bypass switch QS2 on UPS units. Press  to proceed to next stage.
WAIT BYPASS OK THEN PRESS BUZZER	Request for intervention	Wait for acknowledgement of Bypass OK. Press  to proceed to next stage.
CHECK BYPASS NUMBER THEN PRESS BUZZER	Request for verification	Check that the number of Bypass supplies is compatible with current load, bearing redundancy in mind. Press  to proceed to next stage.
WAIT INV.PHASE LOCK THEN PRESS BUZZER	Request for intervention	Wait for sync between Bypass and UPS inverters. Press  to proceed to next stage.
ST.SW.BLK ON INV.? THEN PRESS BUZZER	Request for verification	Check that static switch is not blocked on inverter. Press  to proceed to next stage.
STOP UPS INVERTER THEN PRESS BUZZER	Request for intervention	Stop UPS inverters by pressing pushbutton  for at least 2 seconds. Press  to proceed to next stage.
CLOSE UPS S3 SWITCH THEN PRESS BUZZER	Request for intervention	Close Maint. switch S3 on UPS. Press  to proceed to next stage.
OPEN UPS S4 SWITCH THEN PRESS BUZZER	Request for intervention	Open UPS output switch S4 . Press  to proceed to next stage.
OPEN UPS S2 SWITCH THEN PRESS BUZZER	Request for intervention	Open UPS Bypass switch S2 . Press  to proceed to next stage.
CLOSE UPS S1 SWITCH THEN PRESS BUZZER	Request for intervention	Open UPS input switch S1 . Press  to proceed to next stage.

MANUAL MAINT. BYPASS
PROCEDURE COMPLETE

Request for
intervention

Press  to exit.

System RETURN FROM MAINT. BYPASS procedure

VERIFY NO EPO ACTIVE
THEN PRESS BUZZER

Request for
verification

Verify that E.P.O. is not active. If active, procedure is incompatible and must be suspended.

Press  to proceed to next stage.

CLOSE UPS S2 SWITCH
THEN PRESS BUZZER

Request for
intervention

Close Bypass switch **S2** on UPS units.

Press  to proceed to next stage.

WAIT BYPASS OK
THEN PRESS BUZZER

Request for
intervention

Wait for acknowledgement of Bypass OK.

Press  to proceed to next stage.

CHECK BYPASS NUMBER
THEN PRESS BUZZER

Request for
verification

Check that the number of Bypass supplies is compatible with current load, bearing redundancy in mind.

Press  to proceed to next stage.

STOP UPS INVERTER
THEN PRESS BUZZER

Request for
intervention

Stop UPS inverters by pressing pushbutton  for at least 2 seconds.

Press  to proceed to next stage.

CLOSE UPS S4 SWITCH
THEN PRESS BUZZER

Request for
intervention

Close UPS output switch **S4**.

Press  to proceed to next stage.

ST.SW.BLK ON INV.?
THEN PRESS BUZZER

Request for
verification

Check that static switch is not blocked on inverter.

WARNING: load supply will be interrupted if procedure continued.

Press  to proceed to next stage.

OPEN UPS S3 SWITCH
THEN PRESS BUZZER

Request for
intervention

Open maint. switch **S3** on UPS.

Press  to proceed to next stage.

ST.SW.BLK ON INV.?
THEN PRESS BUZZER

Request for
verification

Check that static switch is not blocked on inverter.

Press  to proceed to next stage.

CLOSE UPS S1 SWITCH
THEN PRESS BUZZER

Request for
intervention

Close UPS input switch **S1**.

Press  to proceed to next stage.

START UPS INVERTER
THEN PRESS BUZZER

Request for
intervention

Start up inverter on UPS units by pressing pushbutton .

Press  to proceed to next stage.

**CHECK INV. NUMBER
THEN PRESS BUZZER**

Request for
verification

Check that number of inverters is compatible with current load, bearing redundancy in mind.

Press  to proceed to next stage.

**ST.SW.BLK ON INV.?
THEN PRESS BUZZER**

Request for
verification

Check that the static switch on UPS is not blocked on inverter.

Press  to proceed to next stage.

**ST.SW.BLK ON BYP.?
THEN PRESS BUZZER**

Request for
verification

Check that static switch is not blocked on Bypass.

Press  to proceed to next stage.

**CHECK LOAD ON INV.
THEN PRESS BUZZER**

Request for
verification

Check that load is on inverter.













Press  to proceed to next stage.

**RETURN FROM MAINT.
BYPASS
PROCEDURE COMPLETE**









Request for
intervention

Press  to exit.



SYSTEM START UP procedure

VERIFY NO EPO ACTIVE THEN PRESS BUZZER	Request for verification	Verify that E.P.O. is not active. If active, procedure is incompatible and must be suspended. Press  to proceed to next stage.
CLOSE UPS S2 SWITCH THEN PRESS BUZZER	Request for intervention	Close Bypass switch S2 on UPS units. Press  to proceed to next stage.
WAIT BYPASS OK THEN PRESS BUZZER	Request for intervention	Wait for acknowledgement of Bypass OK. Press  to proceed to next stage.
CHECK BYPASS NUMBER THEN PRESS BUZZER	Request for verification	Check that the number of Bypass supplies is compatible with current load, bearing redundancy in mind. Press  to proceed to next stage.
CLOSE UPS S4 SWITCH THEN PRESS BUZZER	Request for intervention	Close UPS output switch S4 . Press  to proceed to next stage.
CLOSE UPS S1 SWITCH THEN PRESS BUZZER	Request for intervention	Close UPS input switch S1 . Press  to proceed to next stage.
START UPS INVERTER THEN PRESS BUZZER	Request for intervention	Start up inverter on UPS units by pressing pushbutton  . Press  to proceed to next stage.
CHECK INV. NUMBER THEN PRESS BUZZER	Request for intervention	Check that inverter is compatible with present load, bearing redundancy in mind. Press  to proceed to next stage.
ST.SW. BLK ON INV. ? THEN PRESS BUZZER	Request for verification	Check that static switch on UPS is not blocked on inverter. Press  to proceed to next stage.
ST.SW. BLK ON BYP. ? THEN PRESS BUZZER	Request for verification	Check that static switch on UPS is not blocked on Bypass. Press  to proceed to next stage.
CHECK LOAD ON INV. THEN PRESS BUZZER	Request for verification	Check that load is on inverter. Press  to proceed to next stage.
SYSTEM START UP PROCEDURE COMPLETE	Request for intervention	Press  to exit.

SYSTEM SHUT DOWN procedure

VERIFY NO EPO ACTIVE THEN PRESS BUZZER	Request for verification	Verify that E.P.O. is not active. If active, procedure is incompatible and must be suspended. Press  to proceed to next stage.
OPEN UPS S3 SWITCH THEN PRESS BUZZER	Request for intervention	Open Maint. Bypass switch S3 on UPS units. Press  to proceed to next stage.
OPEN UPS S2 SWITCH THEN PRESS BUZZER	Request for intervention	Open Bypass switch S2 on UPS units. Press  to proceed to next stage.
STOP UPS INVERTER THEN PRESS BUZZER	Request for intervention	Switch off UPS inverter by pressing pushbutton  for at least 2 seconds. Press  to proceed to next stage.
OPEN UPS S4 SWITCH THEN PRESS BUZZER	Request for intervention	Open UPS output switch S4 . Press  to proceed to next stage.
OPEN UPS S1 SWITCH THEN PRESS BUZZER	Request for intervention	Open input switch S1 on UPS units. Press  to proceed to next stage.
SYSTEM SHUT DOWN PROCEDURE COMPLETE	Request for intervention	Press  to exit.

Single UPS START UP procedure

UPS START UP E.P.O. ACTIVE	Indication	Procedure not possible while E.P.O. is active.
UPS START UP CLOSE SWITCH S1	Request for intervention	Close input switch S1 .
UPS START UP WAIT V _{dc} IN RANGE	Indication	The system waits for the rectifier dc output voltage to reach 2 V/cell.
UPS START UP CLOSE S2 SWITCH	Request for intervention	Close Bypass switch S2 .
UPS START UP WAIT BYPASS OK	Indication	System awaiting Bypass OK.
UPS START UP CLOSE S4 SWITCH	Request for intervention	Close output switch S4 .
UPS START UP START INVERTER	Request for intervention	Start inverter, press pushbutton 
UPS START UP WAIT INVERTER START	Indication	System is awaiting inverter drive. Inverter will not start in the following conditions: -- inverter frequency does not reach nominal value (i.e. 1% of tolerance) during Bypass failure; -- battery contactor is not closed.
UPS START UP INVERTER INHIBITED	Indication	Inverter is disabled.
UPS START UP INVERTER BLOCKED	Indication	Inverter is blocked.
UPS START UP ST.SW.BLOCKED ON INV	Indication	Static switch is blocked on inverter.
UPS START UP ST.SW.BLOCKED ON BYP	Indication	Static switch is blocked on Bypass (load is not on inverter).
UPS START UP WAIT LOAD ON INV.	Indication	System is waiting for load on inverter.
UPS START UP PROCEDURE COMPLETE	Request for intervention	Press  to exit.

Single UPS SHUT DOWN procedure

UPS SHUT DOWN E.P.O. ACTIVE	Indication	Procedure not possible while E.P.O. is active.
UPS SHUT DOWN OPEN S3 SWITCH	Request for intervention	Open Maint. Bypass switch S3 .
UPS SHUT DOWN OPEN S2 SWITCH	Request for intervention	Open Bypass switch S2 .
UPS SHUT DOWN STOP INVERTER	Request for intervention	Stop inverter pressing pushbutton ⊙ for at least 2 seconds
UPS SHUT DOWN OPEN S4 SWITCH	Request for intervention	Open output switch S4 .
UPS SHUT DOWN OPEN S1 SWITCH	Request for intervention	Open input switch S1 .
UPS SHUT DOWN PROCEDURE COMPLETE	Request for intervention	Press ⊙ to exit.

10. EDP 90 I/O Functions

10.1 Description of input/output functions

The UPS in the EDP 90 series are equipped with a program capable of managing a certain number of input/output functions already included by the factory, which allow the user to adapt the UPS to his own needs, taking advantage of the input or output contacts available on the UPS terminal board.

10.2 Available functions

The available functions differ according to the type of machine: single or parallel.

Below is a list of the functions available on each of the above types of machine.

NOTE: Note that in Tables 5/6 each function is identified by a letter (A, B, etc.).

This code is necessary since the functions will be identified by these letters on the LCD machine display.

Table 5 - List of individual UPS functions

	Function name	Description	Number of inputs used	Number of outputs used
A	Common vented (wet) batteries	The controls for battery tests or rapid charging are transmitted or received through two input and two output contacts for UPS that share the same battery.	2	2
B	Common VRLA (sealed) batteries	The controls for battery tests are transmitted or received through one input and one output contact for UPS that share the same battery.	1	1
C	Fan (ON-OFF) in battery compartment	A contact is activated to control a fan in the battery compartment, which will function as follows: 1) The fan will be turned on when a set temperature threshold is exceeded (default 30°C/86°F), and will remain on for a set minimum time (default 1 hour). 2) For batteries with rapid charging function, the contact is activated during this process, and will be kept on for an adjustable additional minimum time (default 1 hour).	0	1
D	Battery fuse monitor	When the input is active, the message " BATTERY FUSE BLOWN " will appear on the battery alarm page.	1	0
E	Battery compartment overheated	A contact is activated when a temperature threshold set by the customer is exceeded. The default setting is 30° C (86°F).	0	1
F	Battery temperature outside tolerance	A contact is activated when the temperature is beyond the normal operating range of the battery (0° - 40°C / 32° - 104°F).	0	1
G	Battery earth fault	When this input is activated, with the rectifier off or with a UPS included in an isolated system, the message " INSULATION FAILURE " appears on the battery alarm page and an output contact is activated.	1	1
H	Input earth fault	When this input is activated the message " INSULATION FAILURE " appears on the rectifier alarm page.	1	0

	Function name	Description	Number of inputs used	Number of outputs used
I	Micro Switch Ups doors	When this input is activated, the remote controls that would vary the UPS status available through the EASY and LIFE options are deactivated. The message " REMOTE CMD INHIBITED " also appears on the system alarm page.	1	0
M	Generator on	When this input is activated, battery charging is inhibited and the message " BATT. CHARGE INHIBIT " appears on the rectifier alarm page.	1	0
N	Hydrogen present	When this input is activated, battery charging is inhibited and the message " BATT. CHARGE INHIBIT " appears on the rectifier alarm page.	1	0
O	Remote inverter stop	When this input is activated, the inverter is turned off according to the same procedures by which the inverter is shut off using the mimic panel, and the message " REMOTE INV. STOPPED " appears on the inverter alarm page.	1	0
P	Output earth fault	When this input is activated the message " INSULATION FAILURE " appears on the load alarm page.	1	0
Q	Bypass input transformer protection	When this input is activated the message " BYP. TRANSF. PROTECT " appears on the Bypass alarm page.	1	0
R	Utility input transformer protection	When this input is activated the message " UTLY TRANSF. PROTECT " appears on the rectifier alarm page.	1	0
V	Insufficient ventilation	When this input is activated the message " INSUFF. VENTILATION " appears on the system alarm page.	1	0

Table 6 - List of parallel UPS functions

	Function name	Description	Number of inputs used	Number of outputs used
A	Common vented (wet) batteries	The controls for battery tests or rapid charging are transmitted or received through two input and two output contacts for UPS that share the same battery.	2	2
B	Common VRLA (sealed) batteries	The controls for battery tests are transmitted or received through one input and one output contact for UPS that share the same battery.	1	1
C	Fan (ON-OFF) in battery compartment	A contact is activated to control a fan in the battery compartment, which will function as follows: 1) The fan will be turned on when a set temperature threshold is exceeded (default 30°C / 86°F), and will remain on for a set minimum time (default 1 hour). 2) For batteries with rapid charging function, the contact is activated during this process, and will be kept on for an adjustable additional minimum time (default 1 hour).	0	1
D	Battery fuse monitor	When the input is active, the message " BATTERY FUSE BLOWN " will appear on the battery alarm page.	1	0
E	Battery compartment overheated	A contact is activated when a temperature threshold set by the customer is exceeded. The default setting is 30° C (86°F).	0	1
F	Battery temperature outside tolerance	A contact is activated when the temperature is beyond the normal operating range of the battery (0° - 40°C / 32° - 104°F).	0	1
G	Battery earth fault	When this input is activated, with the rectifier off or with a UPS included in an isolated system, the message " INSULATION FAILURE " appears on the battery alarm page and an output contact is activated.	1	1
H	Input earth fault	When this input is activated the message " INSULATION FAILURE " appears on the rectifier alarm page.	1	0

	Function name	Description	Number of inputs used	Number of outputs used
I	Micro Switch Ups doors	When this input is activated, the remote controls that would vary the UPS status available through the EASY and LIFE options are deactivated. The message " REMOTE CMD INHIBITED " also appears on the system alarm page.	1	0
M	Generator on	When this input is activated, battery charging is inhibited and the message " BATT. CHARGE INHIBIT " appears on the rectifier alarm page.	1	0
N	Hydrogen present	When this input is activated, battery charging is inhibited and the message " BATT. CHARGE INHIBIT " appears on the rectifier alarm page.	1	0
O	Remote inverter stop	When this input is activated, the inverter is turned off according to the same procedures by which the inverter is shut off using the mimic panel, and the message " REMOTE INV. STOPPED " appears on the inverter alarm page.	1	0
P	Output earth fault	When this input is activated the message " INSULATION FAILURE " appears on the load alarm page.	1	0
Q	Bypass input transformer protection	When this input is activated the message " BYP. TRANSF. PROTECT " appears on the Bypass alarm page.	1	0
R	Utility input transformer protection	When this input is activated the message " UTLY TRANSF. PROTECT " appears on the rectifier alarm page.	1	0
S	MAINT. BYPASS switch closed	In distributed parallel systems with optional SBS, this function detects the status of the Manual MAINT. BYPASS switch. The message " SYS. BYPASS SW CLOSED " is displayed on the load alarm page.	1	0
T	MAINT. BYPASS switch open	In distributed parallel systems with optional SBS, this function detects the status of the System Output switch. The message " SYSTEM OUTPUT SW OPEN " is displayed on the load alarm page.	1	0
V	Insufficient ventilation	When this input is activated the message " INSUFF. VENTILATION " appears on the system alarm page.	1	0

10.3 How to activate the functions

In order to activate a function, proceed as follows to enter the setup environment:

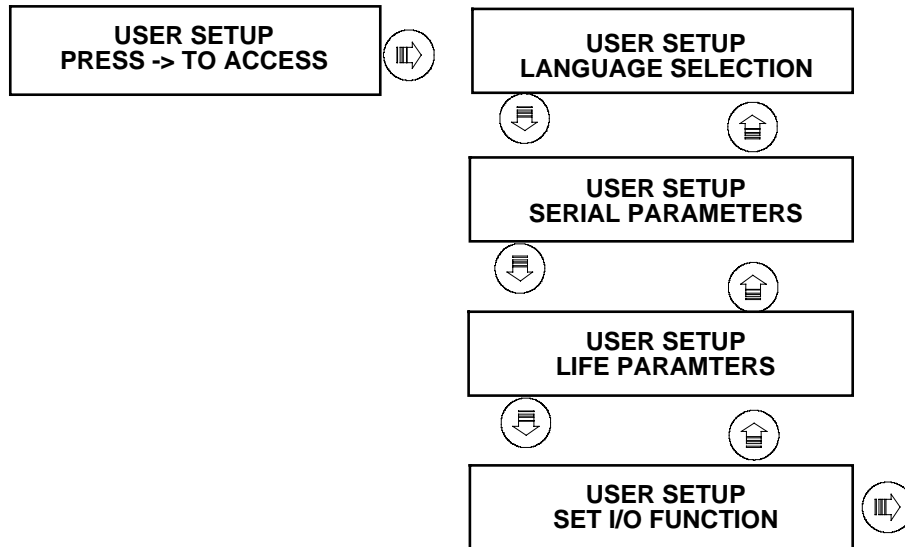

the following page will be displayed when the right arrow is pressed:

```

* FUNCTION A
  DISABLED
  
```

The first line shows the name of the function.

The second line shows the status of the function.

The asterisk in the first line indicates that the function editor is in status display mode. Press the down arrow to display the status of the next function, until all have been shown.

Now let us see how to activate a function.

The following page will be displayed when the right arrow is pressed:

```

FUNCTION A
* DISABLED
  
```

As you will note, the asterisk is placed in the second line to indicate that the function editor is in status change mode.

Press the up or down arrow to change the status of the function from OFF to ON.

If we press the right arrow when the function is OFF, the function editor will return to display mode; if instead we press it when the function is ON, the following page appears:

```

FUNCTION A
Input 0 * Positive
  
```

This page allows us to set the polarity of the input signal used by the function, by pressing the up or down arrows.

There is quite a bit of information contained in the second line:

Input 0 this indicates that we are working on the first input of the function, if the function requires more than one input, the following pages will display input 1, and so forth.

The asterisk indicates that the function editor is in change mode.

Positive indicates the polarity with which the input in question is handled.

To better understand the meaning of polarity, let us consider the following example:

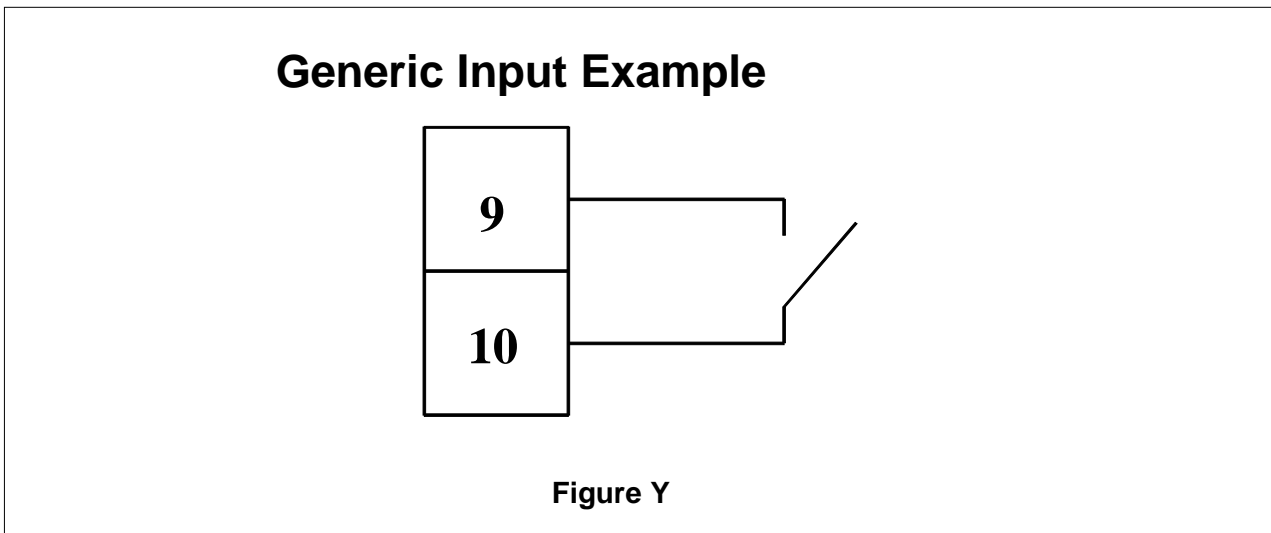

If we have an input connected to a voltage-free, normally-open contact we can change the polarity of the signal so that this input is interpreted differently while using the same type of wiring. For example, if we set the polarity to POSITIVE, the input in Fig. Y will be interpreted by the program as an ON condition, while if we set the polarity to NEGATIVE, the input in Fig. Y will be interpreted as an OFF condition.

Follow the table below to set the polarity of an input.

INPUT STATUS	POLARITY	Software CONDITION
CLOSED	POSITIVE	OFF
OPEN	POSITIVE	ON
CLOSED	NEGATIVE	ON
OPEN	NEGATIVE	OFF

After setting the polarity of the input signal in question, press the right arrow. If the function uses more than one input signal, the program will ask the user to set the polarity as described above.

For example, function A is made up of two inputs, and thus the following page will appear:

FUNCTION A
Input 1 * Positive

Once the input polarities have been set, if the function also uses output signals the following page will appear when the right arrow is pressed:

FUNCTION A
Output 0 * Positive

This page allows us to set the polarity of the signal used by the function, by pressing the up or down arrows.

There is quite a bit of information contained in the second line:

Output 0 this indicates that we are working on the first output of the function, if the function requires more than one output, the following pages will display output 1, and so forth.

The asterisk indicates that the function editor is in change mode.

Positive indicates the polarity with which the output in question is activated.

To better understand the meaning of polarity, let us consider the following example:

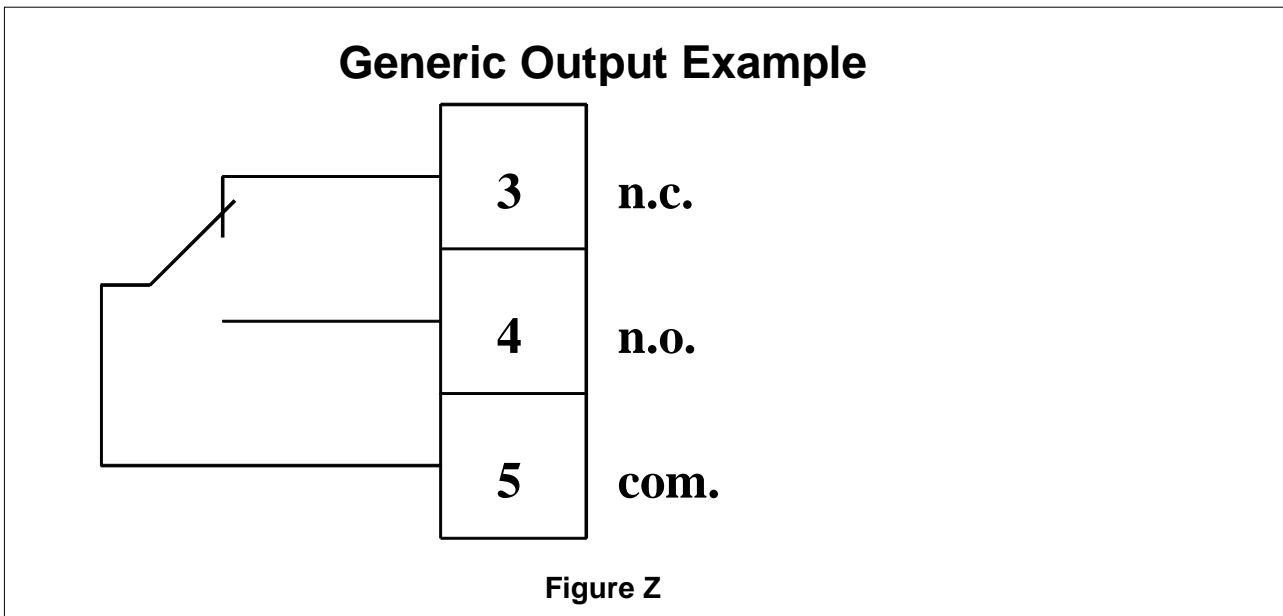

If we use an output such as the one shown in Fig. Z, we can change the output signal polarity to have a positive- or negative-security contact.

NEGATIVE SECURITY This is obtained by setting the polarity to POSITIVE. The relay is activated when the output is in alarm (closed contact on N.O.).

POSITIVE SECURITY This is obtained by setting the polarity to NEGATIVE. The relay is off when the output is in alarm (closed contact on N.C.). This means that the contact is also closed when the coil is not powered or broken.

Follow the table below for setting the polarity of an output.

Software CONDITION		POLARITY	RELAY STATUS	TYPE OF SECURITY
ON	(In alarm)	POSITIVE	ON	NEGATIVE
OFF	(Not in alarm)	POSITIVE	OFF	
ON	(In alarm)	NEGATIVE	OFF	POSITIVE
OFF	(Not in alarm)	NEGATIVE	ON	

After setting the polarity of the output signal in question, press the right arrow. If the function uses more than one output signal, the program will ask the user to set the polarity as described above.

For example, function A is made up of two outputs, and thus the following page will appear:

<p>FUNCTION A Output 1 * Positive</p>

Once the output polarities have been set, when the right arrow is pressed the program will automatically search for the available inputs and outputs:

<p>*FUNCTION A I0N I1P O0N O1N</p>
--

Note that the asterisk is now positioned in the first line, since the function editor is now in display mode.

When a function is enabled, the second line shows information on how many inputs and outputs it is made up of, which terminals it is assigned to on the terminal board, and its programmed polarity.

Let us take for example the message:

I0N I1P O0N O1N

This indicates that:

- The function is made up of two inputs and two outputs.
- The first input is assigned to the terminal board at user input 0 with negative polarity.
- The second input is assigned to the terminal board at user input 1 with positive polarity.
- The first output is assigned to the terminal board at user output 0 with negative polarity.
- The second output is assigned to the terminal board at user output 1 with negative polarity.

Terminal assignments for individual or parallel UPS

I/O CODE	Number of terminal board contact	Supply
User Input 0	9-10	standard
User Input 1	15-16	standard
User Input 2	36-37	standard
User Input 3	38-39	standard
User Input 4	40-41	standard
User Input 5	42-43	standard
User Output 0	3-4-5	standard
User Output 1	6-7-8	standard
User Output 2	30-31-32	standard
User Output 3	33-34-35	standard

10.4 Description of function wiring with fixed terminal assignments

The input or output signals of some functions are automatically assigned to the terminals so as to always follow the same wiring pattern.

Function A for individual and Parallel UPS

This function is essential when using UPS with vented (wet) common batteries.

Enable function A as follows:

Input 0	NEGATIVE polarity
Input 1	NEGATIVE polarity
Output 0	POSITIVE polarity
Output 1	NEGATIVE polarity

Wire the UPS together according to the following diagram:

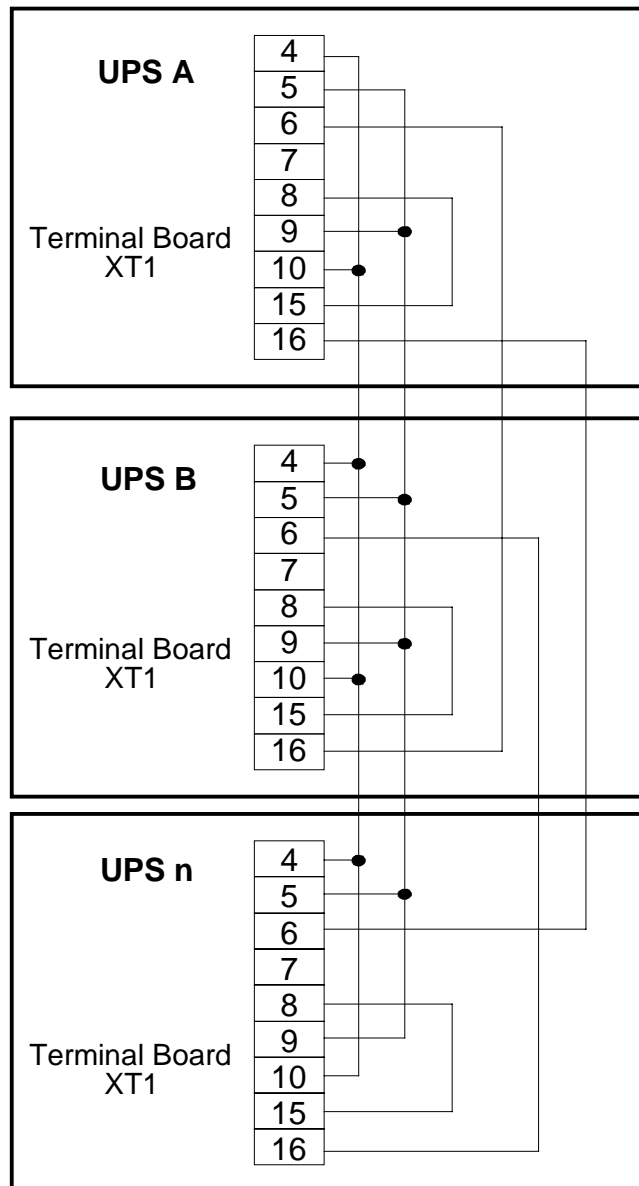

NOTE: With this option it is also necessary to set a parameter in the Setup environment under the item CONF. RECT PARAMETER, as described in the TECHNICAL HANDBOOK.

Function B for individual and Parallel UPS

This function is essential when using UPS with VRLA (sealed) common batteries.
Enable function B as follows:

Input 0 NEGATIVE polarity
Output 0 POSITIVE polarity

Wire the UPS together according to the following diagram:

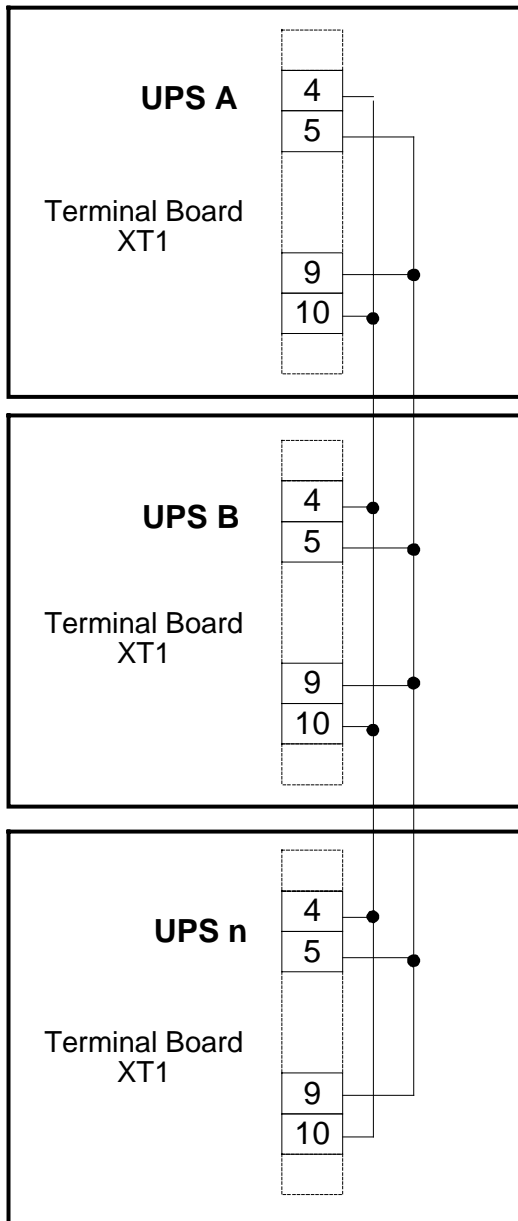

NOTE: With this option it is also necessary to set a parameter in the Setup environment under the item CONF. RECT PARAMETER, as described in the TECHNICAL HANDBOOK.

Functions S and T for parallel UPS with SBS

In the case of distributed parallel with SBS, program the S and T functions as follows:

Function S

Input 0 POSITIVE polarity

Function T

Input 0 POSITIVE polarity

Wire the UPS and SBS together according to the following diagram:

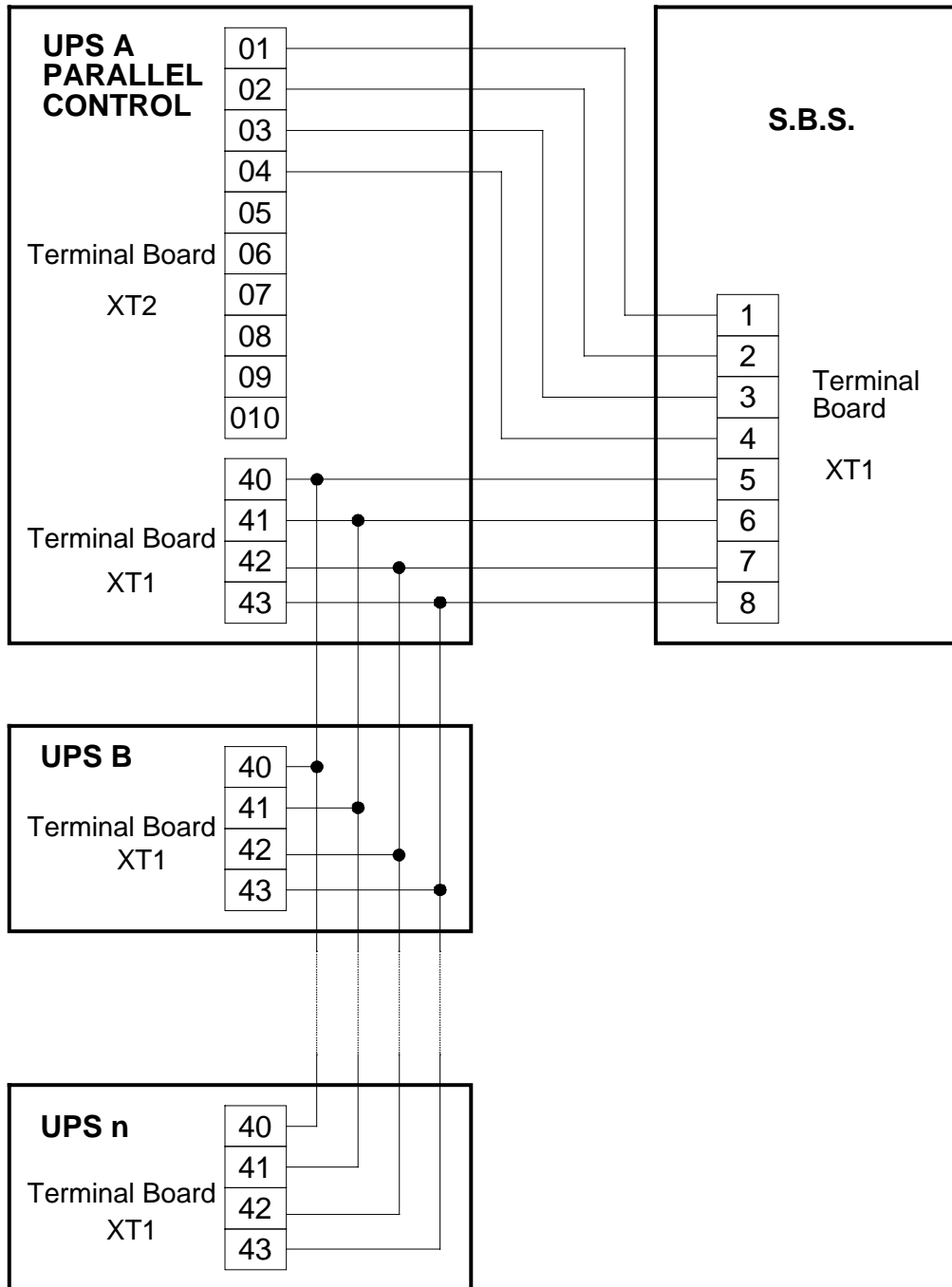

10.5 Battery isolation leakage

For this option, if the UPS is included in an isolated system, a value must also be changed in the Setup environment under the item CONF. RECT PARAMETER.

10.6 Electrical specifications of input/output signals

The output terminals are voltage-free (Max. 1 Amp 30 V AC/DC - contact resistance = 100 mohm).

The Input terminals need simply to be connected to voltage-free contacts.

If the input comes from a relay, the minimum contact current of the latter must be 15 mAmp.

10.7 Table of functions

The following tables list the functions activated on the individual or parallel UPS.

These tables are given when necessary in the inspection report that accompanies each UPS.

The options must be activated in sequence (i.e., if the options to be activated are G-C-I, one must first activate option C, then option G, and finally option I).

The user inputs and user outputs are assigned to the terminal board using the first free terminal on the left-hand side of the table.

The INPUT polarities must be assigned keeping in mind the type of contact available to the customer and how it is recognized by the UPS software.

The OUTPUT polarities must be assigned keeping in mind what condition it is given by the UPS software and what type of SECURITY the customer desires.

10.8 Table of Functions activated on individual or parallel UPS

INPUT												
USER No	USER 0		USER 1		USER 2		USER 3		USER 4		USER 5	
XT1	9	10	15	16	36	37	38	39	40	41	42	43
A	N	P	N	P	N	P	N	P	N	P	N	P
B	N	P	N	P	N	P	N	P	N	P	N	P
C	N	P	N	P	N	P	N	P	N	P	N	P
D	N	P	N	P	N	P	N	P	N	P	N	P
E	N	P	N	P	N	P	N	P	N	P	N	P
F	N	P	N	P	N	P	N	P	N	P	N	P
G	N	P	N	P	N	P	N	P	N	P	N	P
H	N	P	N	P	N	P	N	P	N	P	N	P
I	N	P	N	P	N	P	N	P	N	P	N	P
L	N	P	N	P	N	P	N	P	N	P	N	P
M	N	P	N	P	N	P	N	P	N	P	N	P
N	N	P	N	P	N	P	N	P	N	P	N	P
O	N	P	N	P	N	P	N	P	N	P	N	P
P	N	P	N	P	N	P	N	P	N	P	N	P
Q	N	P	N	P	N	P	N	P	N	P	N	P
R	N	P	N	P	N	P	N	P	N	P	N	P
S	N	P	N	P	N	P	N	P	N	P	N	P
T	N	P	N	P	N	P	N	P	N	P	N	P
V	N	P	N	P	N	P	N	P	N	P	N	P

N = Negative Polarity

P = Positive Polarity

CAUTION:

The functions on a grey background indicate options with fixed terminal assignment as described previously.

XT1 terminals 30 through 43 are optional in UPS up to 200kVA.

OUTPUT												
USER No	USER 0			USER 1			USER 2			USER 3		
XT1	3	4	5	6	7	8	30	31	32	33	34	35
A	N	P		N	P		N	P		N	P	
B	N	P		N	P		N	P		N	P	
C	N	P		N	P		N	P		N	P	
D	N	P		N	P		N	P		N	P	
E	N	P		N	P		N	P		N	P	
F	N	P		N	P		N	P		N	P	
G	N	P		N	P		N	P		N	P	
H	N	P		N	P		N	P		N	P	
I	N	P		N	P		N	P		N	P	
L	N	P		N	P		N	P		N	P	
M	N	P		N	P		N	P		N	P	
N	N	P		N	P		N	P		N	P	
O	N	P		N	P		N	P		N	P	
P	N	P		N	P		N	P		N	P	
Q	N	P		N	P		N	P		N	P	
R	N	P		N	P		N	P		N	P	
S	N	P		N	P		N	P		N	P	
T	N	P		N	P		N	P		N	P	
V	N	P		N	P		N	P		N	P	

11. BATTERY TEST

The EDP90 has an automatic battery test function to test its status without interfering with the continuous power supply.

The software automatically performs the test every 7 days minus 5 hours since the last test or after the machine is turned on.

To avoid testing a discharged battery, the automatic BATTERY TEST is inhibited for 2 days following one of the following situations:

- Utility power failure
- QS1 input switch open
- battery discharged
- bridge control fault.

The test takes one minute to run, during which the battery voltage is kept under constant control; if it falls below the minimum voltage allowed for the battery test, the test is terminated and the BATTERY ERROR alarm is activated; if not, no alarm is activated.

During the automatic BATTERY TEST, the display shows the message:

**UPS xxx kVA
AUTO TEST**

When the test is complete, it will display the message:

**UPS xxx kVA
SYSTEM NORMAL**

The BATTERY TEST may also be initiated manually.

To launch the BATTERY TEST manually, when the display shows the message:

**UPS xxx kVA
SYSTEM NORMAL**

Press the  button until the following message appears:

**SPECIAL FUNCTION
PRESS -> TO ACCESS**

Then press ; the message:

**GUIDED PROCEDURES
PRESS -> TO ACCESS**

At this point, press the  button twice so that the display reads:

**TEST BATTERY
PRESS -> TO START**

The BATTERY TEST will start when the  button is pressed, and the following message will appear:

**UPS xxx kVA
AUTO TEST**

At the end of the test, the display will automatically read:

**UPS xxx kVA
SYSTEM NORMAL**

11.1 AUTONOMY TEST

The EDP90 is equipped with a battery AUTONOMY TEST function which manually turns off the rectifier. When the battery has reached the end of its autonomy, the inverter stops and the load transfers to Bypass. The rectifier then starts again, as does the inverter when the direct voltage reaches its rated value.

If the Bypass supply encounters problems while the AUTONOMY TEST is being performed, the test is automatically terminated.

To initiate the AUTONOMY TEST when the display shows the message:

**UPS xxx kVA
SYSTEM NORMAL**

press the  button until the following message appears:

**SPECIAL FUNCTION
PRESS -> TO ACCESS**

Then press ; the message:

**GUIDED PROCEDURES
PRESS -> TO ACCESS**

will appear.

At this point, press the  button 3 times so that the display reads:

**TEST AUTONOMY
PRESS -> TO START**

The AUTONOMY TEST will start when the  button is pressed, and the following message will appear:

**UPS xxx kVA
SYSTEM IN ALARM**

In order to manually interrupt the AUTONOMY TEST, repeat the procedure described above until the following message is displayed:

**AUTONOMY TEST
PRESS -> TO STOP**

Press  to interrupt the AUTONOMY TEST; the rectifier will start again automatically. After approximately 15", the display will automatically show the message:

**UPS xxx kVA
SISTEM NORMAL**

12. COMPUTER INTERFACE

12.1 INTERFACE CONNECTORS

The EDP90 is fitted with four interface connectors, which are located on the inside of the left foot of the UPS (see Fig. AA).

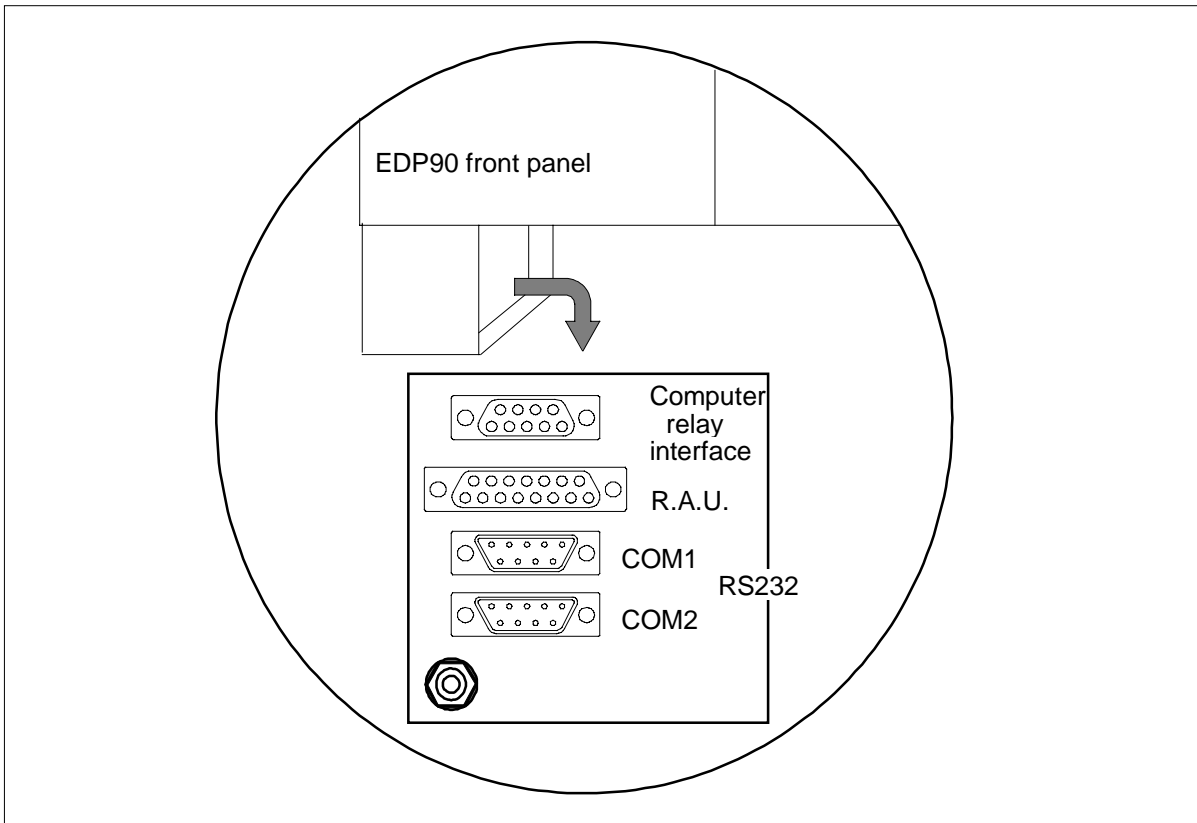

Figure AA - Interface connectors

14.2 AS400™

The EDP90 UPS is fitted with a 9 pin D connector for direct connection to an IBM AS/400™ computer (see fig. BB).

The interfacing system may also be used for ON/OFF control with any software system connected to the UPS.

The functions of the connector pins are described below:

No. PIN	DESCRIPTION	FUNCTION
8	SYSTEM NORMAL	UPS in operation -> load supplied by UPS.
6	LOAD ON BYPASS	Load is supplied by Bypass line.
9	UTILITY SUPPLY FAILURE	Failure in supply to the UPS unit.
7	BATTERY LOW	Battery autonomy is low; inverter will shut down, load will be automatically transferred to Bypass supply (if available).
5	COMMON	When any of the above situations is manifested, relevant pin is connected to the common pin (5).

Figure BB - Pin layout in AS400 computer interface

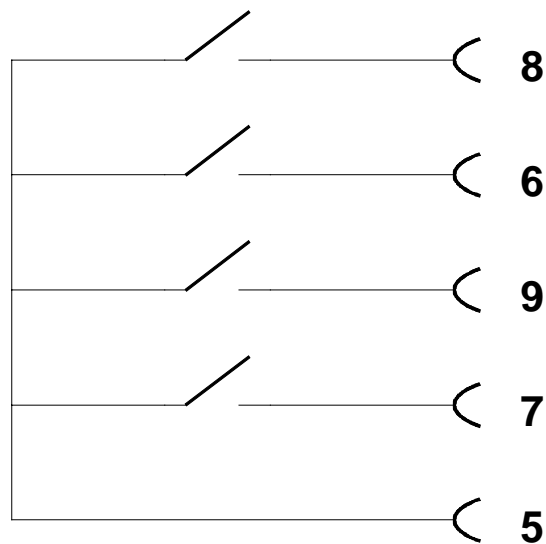

N.B. Under normal operating conditions pin 8 contact is closed, while the contacts of pins 6, 7 and 9 are open.

12.3 RS232 - COM1

The EDP90 UPS is fitted with a 9 pin D plug, which enables communication between the UPS microprocessor and a computer.

This link up permits "EASY 10/1000" and "LIFE" (Chloride) software to be run on an IBM compatible computer.

Pin functions:

Pin 1	DCD	(Data Carrier Detect)
Pin 2	RXD	(Received data)
Pin 3	TXD	(Transmitted data)
Pin 4	DTR	(Data terminal ready)
Pin 5	GND	(Ground)
Pin 6	DSR	(Data Set Ready)
Pin 7	RTS	(Request To Send)
Pin 8	CTS	(Clear To Send)

Pin functions comply with EIA RS232 standard specifications.

12.4 RS232 - COM2

The EDP90 UPS is fitted with a 9 pin D plug, which enables communication between the UPS microprocessor and a computer.

This link up permits "EASY 10/1000" and "LIFE" (Chloride) software to be run on an IBM compatible computer.

Pin functions:

Pin 1	DCD	(Data Carrier Detect)
Pin 2	RXD	(Received data)
Pin 3	TXD	(Transmitted data)
Pin 4	DTR	(Data terminal ready)
Pin 5	GND	(Ground)
Pin 6	DSR	(Data Set Ready)
Pin 7	RTS	(Request To Send)
Pin 8	CTS	(Clear To Send)
Pin 9	RI	(Ring Indicator)

Pin functions comply with EIA RS232 standard specifications.

13. REMOTE ALARMS

Remote indication of EDP90 status is provided by a 15 pin D socket. These indications may be connected to the Chloride Remote Alarms Panel. Pin functions:

Figure CC

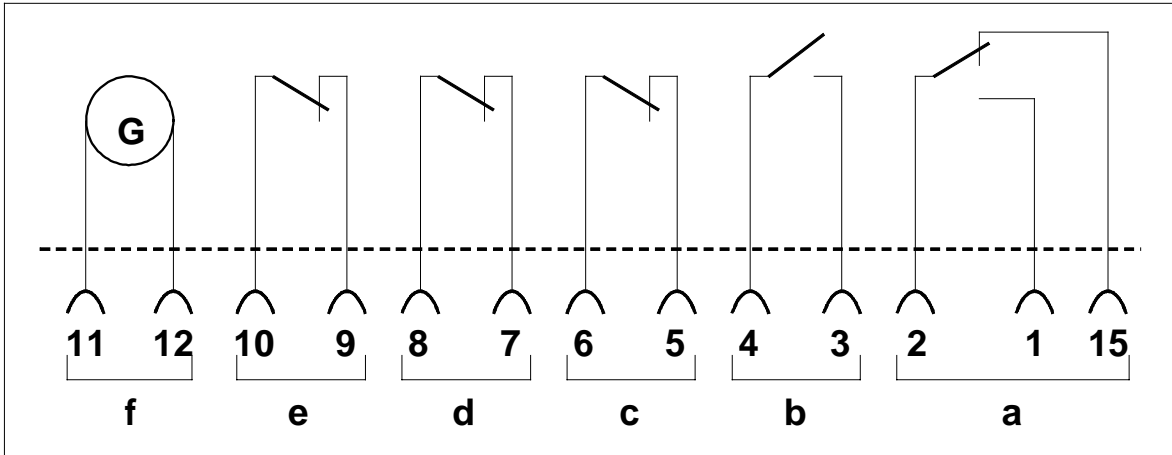

a) SYSTEM NORMAL / SUMMARY ALARM

NORMAL OPERATION	terminals 1-2 closed	terminals 2-15 open
ALARM OPERATION	terminals 1-2 open	terminals 2-15 closed

b) INVERTER BREAKDOWN

INVERTER OK	terminals 3-4 closed
INVERTER FAULT OR STOPPED	terminals 3-4 open

c) LOAD ON BYPASS

INVERTER-TO LOAD	terminals 5-6 closed
BYPASS-TO LOAD	terminals 5-6 open

d) NO UTILITY SUPPLY

UTILITY SUPPLY PRESENT	terminals 7-8 closed
UTILITY SUPPLY ABSENT	terminals 7-8 open

e) STOP IMMINENT

BATTERY VOLTAGE FAR FROM SHUTDOWN POINT (BATTERY VOLTAGE OK).
terminals 9-10 closed
BATTERY VOLTAGE NEAR TO SHUTDOWN POINT
terminals 9-10 open

f) POWER SUPPLY

18V/200 mA rated AC output.

Signals from pins 1, 2 and 15 may be used for remote indication of SYSTEM NORMAL/SUMMARY ALARM as an alternative to the Remote Alarms Panel. All pins are voltage free contacts, with 0.5A / 30V capacity.

OBSERVATIONS BY THE USER

Our Company continues in its efforts to make this manual use as simple as possible.

For this reason, we invite you, the user, to inform us of any inaccuracies or to use omitted aspects in this handbook, as well as of any comments or suggestions that you may have which could be used to improve the quality of our manuals.

Please make use of the space below; if possible, indicate page and paragraph number.

OBSERVATIONS:.....

NAME.....
PROFESSION.....
ADDRESS.....

CHLORIDE
POWER ELECTRONICS
126 Chloride Road
Burgaw
N.C. 28425
U.S.A.

